

CARPINTERIA VALLEY WATER DISTRICT



PROPOSAL, CONTRACT AND SPECIFICATIONS FOR POTHOLING SERVICES FOR THE CARPINTERIA ADVANCED PURIFICATION PROJECT

PREPARED BY:

Water Systems Consulting, Inc.
805 Aerovista Lane, Suite 201
San Luis Obispo, CA 93401

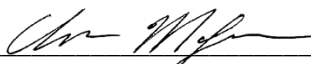

By: Chris Malejan, P.E. Date: 09/20/2023

TABLE OF CONTENTS

TABLE OF CONTENTS	i
SECTION A - BID INFORMATION & DOCUMENTS	1
SECTION A1 - NOTICE AND INVITATION TO SUBMIT SEALED CONSTRUCTION COST PROPOSAL (BID).....	2
SECTION A2 - INSTRUCTIONS TO BIDDERS.....	4
SECTION A3 - BID DOCUMENTS	10
CONTRACTOR'S PROPOSAL	11
BID SCHEDULE	12
BIDDER'S STATEMENT REGARDING INSURANCE COVERAGE	13
LIST OF SUBCONTRACTORS AND SUPPLIERS	14
PROPOSED EQUIPMENT AND MATERIAL MANUFACTURERS	15
BIDDER INFORMATION	16
SUPPLEMENTAL BIDDER INFORMATION	18
EXPERIENCE STATEMENT	19
NON-COLLUSION AFFIDAVIT	20
SECTION A4 - CONTRACT DOCUMENTS	21
CONTRACT AGREEMENT	22
PAYMENT BOND	31
PERFORMANCE BOND	33
INSURANCE REQUIREMENTS FOR CONTRACTORS	35
SECTION B - GENERAL PROVISIONS MODIFICATIONS	38
B1.01 STANDARD SPECIFICATIONS	38
B1.02 MODIFICATIONS TO STANDARD SPECIFICATIONS.....	38
SECTION C - SPECIAL PROVISIONS – TECHNICAL.....	68
SECTION 900 – GENERAL.....	69
SECTION 1000 – UNDERGROUND UTILITY INVESTIGATION	76
ATTACHMENT A – CITY OF CARPINTERIA ENCROACHMENT PERMIT APPLICATION FORMS AND STANDARDS	79
ATTACHMENT B – POTHOLE LOCATION MAP.....	80
ATTACHMENT C – POTHOLE INFORMATION FORM	81

SECTION A - BID INFORMATION & DOCUMENTS

SECTION A1 - NOTICE AND INVITATION TO SUBMIT SEALED CONSTRUCTION COST
PROPOSAL (BID)
FOR
**POTHOLING SERVICES FOR THE CARPINTERIA ADVANCED
PURIFICATION PROJECT**

FOR THE CARPINTERIA VALLEY WATER DISTRICT
SANTA BARBARA COUNTY, CALIFORNIA

PUBLIC NOTICE IS HEREBY GIVEN that the CARPINTERIA VALLEY WATER DISTRICT (CVWD), invites sealed bids for POTHOLING SERVICES FOR THE CARPINTERIA ADVANCED PURIFICATION PROJECT (Project or Work) and will receive such bids by email to Brian@cvwd.net up to the hour of **2:00 pm, on October 12, 2023**. The Board intends to solicit proposals or bids from contractors qualified to perform the necessary Work and satisfactorily and timely complete the Project, and to make an award to the lowest responsible, responsive proposer.

As part of the Carpinteria Advanced Purification Project, a water transmission main is currently being designed and will be constructed. It will convey purified water from an advanced water purification facility to injection wells, in the City of Carpinteria, CA. CVWD has directed, with these documents, potholing at strategic locations along the proposed pipeline alignment to inform the pipeline design.

The work includes obtaining encroachment permit(s) from the City of Carpinteria, creation and implementation of a traffic control plans, potholing utilities in paved areas in the public right-of-way, documenting location, depth, and other pertinent information of underground utilities, backfilling, and restoring pavement. The project duration is limited to 30 working days.

Questions regarding the Bid and Contract Documents content should be directed to Chris Malejan at cmalejan@wsc-inc.com and Brian King at Brian@cvwd.net.

Any contract entered into pursuant to this notice will incorporate the provisions of the State Labor Code. Compliance with the prevailing rates of wages and apprenticeship employment standards established by the State Director of Industrial Relations will be required. The California Prevailing Rates of per diem wages are on file in the office of the Secretary of the Board.

The Board hereby affirmatively ensures that the business enterprises will be afforded the opportunity to submit bids in response to this notice and have not been discriminated against on the basis of race, color, national origin, ancestry, sex, sexual orientation, physical handicap, marital status or religion in any consideration leading to the award of the contract.

Bids must be prepared on the provided Proposal forms in conformance with the Instructions to Bidders and submitted by email with the following subject heading, " BID FOR POTHOLING SERVICES FOR CAPP." No Bid Bond is required.

The contract will not be awarded to a Contractor who does not hold a valid and appropriate Contractor's License at the time of bid submission in accordance with the provisions of the Business and Professions Code.

In accordance with California Public Contract Code Section 22300, the Contractor will have the

option of posting securities of equal or greater value in lieu of a cash retention.

The Board reserves the right to reject any or all bids, the right to make no award whatsoever, the right to waive any irregularity, and the right to take all bids under advisement for a period of sixty (60) calendar days following the bid opening date. The Contractor shall guarantee their prices for this 60-day period, and for the duration of the contract.

BY ORDER OF the CARPINTERIA VALLEY WATER DISTRICT, Santa Barbara County, California.

SECTION A2 - INSTRUCTIONS TO BIDDERS

A2.01 Inspection of Site of Work

Bidders are required to inspect the site of the work in order to satisfy themselves, by personal examination or by such other means as they may prefer, of the location of the proposed work and as to the actual conditions of and at the site of work. If, during the course of his examination, a bidder finds facts or conditions which appear to him to conflict with the letter or spirit of the Contract Documents, or with any other data furnished him, he may apply in writing to Board for additional information and explanation before submitting his bid. Responses will be in the form of written Addendum to Contract Documents and distributed to all bidders.

The submission of a proposal by the bidder shall constitute the acknowledgment that, if awarded the contract, he has relied and is relying on his own examination of (a) the site of the work, (b) the access to the site, and (c) all other data, matters, and things requisite to the fulfillment of the work and on his own knowledge of existing services and utilities on and in the vicinity of the site of the work to be constructed under the contract, and not on any representation or warranty of Board. No claim for additional compensation will be allowed which is based upon a lack of knowledge of the above items.

A2.02 Examination of Contract Documents

Prior to bid submission, each bidder shall thoroughly examine and be familiar with legal and procedural documents, general conditions, specification drawings and addenda (if any). The bidder shall report any errors or omissions noted to the Board. The submission of a proposal shall constitute an acknowledgment upon which the Board may rely that the bidder has thoroughly examined and is familiar with the Contract Documents. The failure or neglect of a bidder to receive or examine any of the Contract Documents shall in no way relieve him from any obligations with respect to his proposal or to the contract. No claim for additional compensation will be allowed which is based upon a lack of knowledge of any Contract Document.

A2.03 Interpretation of Contract Documents

No oral interpretations will be made to any bidder as to the meaning of the Contract Documents. Requests for an interpretation shall be made in writing and delivered to Board at least ten (10) days before the time announced for opening the proposals. Interpretations by Board will be in the form of an addendum to the Contract Documents and, which issued, will be sent as promptly as is practical to all parties to whom the Contract Documents have been issued. All such addenda shall become part of the contract.

A2.04 Soil Information

The bidders shall make their own deductions and conclusions as to the nature of the materials to be excavated, the difficulties of making and maintaining the required excavations, the difficulties which may arise from subsurface conditions, and of doing any other work affected by the subsurface conditions and shall accept full responsibility therefor.

A2.05 Proposal

Proposals shall be made on the Bid Document forms enclosed as Section A3 of these

specifications with additions as allowed on those forms. All proposals shall give the prices proposed, both in writing and in figures, shall give all other information requested herein, and shall be signed by the bidder or his authorized representatives, with his address. If the proposal is made by an individual, his name, signature and post office address must be shown; if made by firm or partnership, the name and post office address of the firm or partnership and the signature of at least one of the general partners must be shown; if made by a corporation, the proposal shall show the name of the State under the laws of which the corporation is chartered, the name and post office address of the corporation, and the title of the person who signs on behalf of the corporation. If the proposal is made by the corporation, a certified copy of the bylaws or resolution of the board of directors of the corporation shall be furnished showing the authority of the officer signing the proposal to execute contracts on behalf of the corporation.

Bidders are warned against making erasures or alterations of any kind, and proposals which contain omissions, erasures or irregularities of any kind may be rejected. Bids not received by CVWD by **October 12, 2023 at 2:00 PM** will not be opened or considered.

As part of his bid submission, the Contractor must state clearly his license number and expiration date.

A2.06 Addenda

Each proposal shall include specific acknowledgment in the space provided of receipt of all addenda issued during the bidding period. Failure to so acknowledge may result in the proposal being rejected as non-responsive.

A2.07 Bid Prices

Bid prices shall include everything necessary for the completion of construction and fulfillment of the contract including but not limited to furnishing all materials, equipment, tools, plans and other facilities and all management, superintendence, labor and services, except as may be provided otherwise in the Contract Documents. In the event of a difference between a price quoted in words and a price quoted in figures for the same quotation, the words shall be the amount bid.

In preparing bid prices bidder represents that he has carefully examined the Contract Documents and the site where the work is to be performed and that he has familiarized himself with all local conditions and federal, state and local laws, ordinances, rules, and regulations that may affect, in any manner, the performance of the work. The bidder further represents that he has studied all surveys and investigation reports about subsurface and latent physical conditions pertaining to the job site, that he has performed such additional surveys and investigations as he deems necessary to complete the work at his bid price, and that he has correlated the results of all such data with the requirements of the Contract Documents. The submittal of a bid shall be conclusive evidence that the bidder has investigated and is satisfied as to the conditions to be encountered, including locality, uncertainty of weather and all other contingencies, and as to the character, quality, quantities, and scope of the work.

The Contractor will not be reimbursed for work performed for his convenience, or as required to adapt to field conditions, or work outside of that required by the Contract Documents.

A2.08 Taxes and License

Paragraph 7-5 of the SSPWC-2018 Edition shall apply to this Contract. Contractor shall pay all fees or royalties required for prosecution of the Work.

A2.09 Recognition of Bonding Companies [Payment And Performance Bonds]

All bonds provided by the Contractor in this contract must be provided by a California admitted surety insurer licensed to do business in the State of California (as set forth in California Code of Civil Procedure Section 995.010 et. seq.) and with a current A.M. Best's rating no less than A:VII or equivalent or as otherwise approved by Board.

A2.10 Qualification of Bidders

Each bidder and any subcontractor performing work valued at more than 10% of the bid shall complete and provide as part of their bid "Bidder Information," "Supplemental Bidder Information," and "Experience Statement" form listing the five (5) projects that are most comparable to this project that the bidder/subcontractor has completed in the last five (5) years with an owner contact person for each of the five projects. Projects where potholing was part of a larger project will count towards the experience requirement. Any Proposal not complying with this requirement may be rejected without further consideration as non-responsive.

Proposals received from bidders or contractors who lack this minimum experience, or which fail to set forth information sufficient to demonstrate that the contractor meets these minimum requirements, shall be deemed non-responsive and shall not be considered. CVWD retains the ultimate discretion to determine whether a proposal is responsive.

CVWD additionally retains the ultimate discretion to ascertain whether a bidder is responsible, as defined in Public Contract Code Section 1103, i.e. a bidder or contractor who has demonstrated the attribute of trustworthiness, as well as quality, fitness, capacity, and experience to satisfactorily perform the contract.

It is CVWD's intention to award a contract to a proposer who furnishes satisfactory evidence that it possesses the requisite experience and ability, and sufficient capital, facilities and plant to enable the contractor to prosecute the work successfully and properly, and to complete the work within the time limits set forth in the contract.

In the event a bidder is viewed as non-responsive, and a written protest is filed by that bidder, a hearing on that matter will be held consistent with CVWD's Procurement Policy.

A2.11 List of Subcontractors

Each proposal shall have listed on the form provided herewith the name and address of each subcontractor to whom the bidder proposes to sublet portions of the work in excess of one-half of one percent of the total amount of his proposal. For the purpose of this paragraph, a subcontractor is defined as one who contracts with the Contractor to furnish materials and labor, or labor only for the performance of work at the site of the work or who will specially fabricate a portion of the work off the site pursuant to detailed drawings in the Contract Documents. The Board reserves the right to determine whether a listed subcontractor is a "responsible" contractor. [Public Contract

Code Section 4107.]

A2.12 Not Used

A2.13 Modification of Proposal

A modification of a proposal already received will be considered only if the modification is received prior to the time announced for the opening of proposals. All modifications shall be made in writing, executed and submitted in the same form and manner as the original proposal.

A2.14 Postponement of Opening

The Board reserves the right to postpone the date and time for opening of proposals at any time prior to the date and time announced in the Notice Inviting Sealed Bids. The Board also reserves the right to issue material changes, additions, or deletions to the Notice Inviting Sealed Bids, which may result in extension of time for closing of submission of bids in accordance with Public Contract Code Section 4104.5.

A2.15 Disqualification of Bidder

If there is reason to believe that collusion exists among the bidders, none of the bids of the participants in such collusion will be considered. Bidders shall execute and submit non-collusion affidavits with their bids, in accordance with Public Contract Code Section 7106.

A2.16 Rejection of Proposals

The Board reserves the right to reject any proposals which are incomplete, non-responsible, obscure or irregular; any proposals which omit a bid on any one or more items on which the bids are required; and proposals which omit unit prices if unit prices are required; any proposal in which unit prices are unbalanced in the opinion of the Board; any proposals accompanied by insufficient or irregular bid security; and any proposals from bidders who have previously failed to perform properly or to complete on time contracts of any nature and/or are otherwise viewed as non-responsible. Issuance of this invitation for a bid does not commit the Board to proceed with the solicitation process or to award any contract for the Project or any other project. The Board makes no guarantee that an award of contract will be made as a result of this invitation for bid. The Board further reserves to right to accept or reject any proposal, to re-solicit proposals, to waive any informalities or minor technical inconsistencies and/or to delete any requirements from this invitation, when deemed by the Board, in its sole discretion, to be most advantageous to the Board and in its best interests.

Any protests regarding the Bid shall be in writing and filed within one (1) day (24 hours) of CVWD's issuance of the notice of decision to recommend the awarding of the Project to a particular bidder. Any such protest shall be submitted to the General Manager of CVWD.

A2.17 Award of Contract

Subject to the Board's right to take bids under advisement for sixty (60) calendar days after the time announced for opening proposals, the Board intends that it will act either to accept a proposal or to reject all proposals. The acceptance of a proposal will be evidenced by a notice of award of

contract in writing, delivered by mail to the bidder whose proposal is accepted. No other act of the Board shall constitute acceptance of a proposal. The award of contract shall obligate the bidder whose proposal is accepted to furnish performance and payment bonds and evidences of insurance and execute the contract set forth herein. The Board reserves the right to award a contract to the lowest, responsible bid, and the right to make no award to any bidder.

The contractors with the lowest bids will be evaluated based on review of their experience and reports from their references and a recommendation for award will be made to the Board of Directors.

Immediately following the award of contract, the successful Bidder will be required to meet with Board representatives in a "Pre-contract Conference" to review the Contract Documents to ensure that the documents will be properly executed and returned by the Bidder in a form acceptable to the Owner.

A2.18 Not Used

A2.19 Resolution of Construction Claims

Bidders are informed that all construction claims of \$375,000 or less resulting from Public Works contracts with local agencies will be resolved within the requirements of the Public Contracts Code, Section 20104 et seq., which sets forth procedures for mediation and arbitration.

A2.20 Not Used

A2.21 Execution of Contract

The contract agreement shall be executed in duplicate by the successful bidder and returned, together with the contract bonds and evidence of insurance, within ten (10) calendar days after the Notice of Award in Section A2.17, above. After execution by the Board, one original contract shall be returned to the Contractor.

A2.22 Amount of Contract

It is the intent of the Board to award a contract to the lowest responsible bidder. However, the Board reserves the right to make no award to any bidder. The Board also reserves the right to limit the award to certain bid items to be determined after a contractor has been selected but prior to award.

A2.23 Nondiscrimination in Employment

By its submission of a bid, Bidder agrees that it shall not discriminate in its recruiting, hiring, promotion, demotion or termination practices, or discriminate against any prospective or active employee engaged in the work because of race, color, ancestry, national origin, religious creed, sex, sexual orientation, age, marital status, physical disability, mental disability, or medical condition. Bidders must comply with applicable Federal and California laws including, but not limited to, the California Fair Employment and Housing Act, beginning with Government Code, Section 12900, and Labor Code, Section 1735 and the American with Disabilities Act, 42 U.S.C.

and 12101 et seq. In addition, Bidders shall require like compliance by any subcontractors employed on the work.

A2.24 Ineligible Contractors

In accordance with Public Contract Code Section 6109, the Board will not knowingly permit a subcontractor who is “ineligible” for public work pursuant to Labor Code Sections 1777.1 or 1777.7, to perform work as a subcontractor on the project. The Contractor for this project shall not perform work with a subcontractor who is ineligible to perform work on a public works project pursuant to Labor Code Sections 1777.1 or 1777.7.

A2.25 Time of Performance and Liquidated Damages

All work shall be completed within the time stipulated in SECTION A4 - CONTRACT DOCUMENTS after effective date of Notice To Proceed as defined in Section B (General Provisions Modifications) plus any allowed extensions. If the Contractor has not completed all work as determined by the Board within the contract period, liquidated damages will be assessed in accordance with Section 6-9.1 of Section B (General Provisions Modifications), as modified herein, and the Contract Agreement in Section A-4, Article 2.

A2.26 Public Contract Code

CVWD is not subject to the provisions of the California Public Contract Code. Nevertheless, certain sections of the Public Contract Code are referred to in these bid documents, and where referenced, these sections shall govern the subject where used.

A2.27 Gender

The use of the male gender throughout these bid documents is done for convenience and brevity only and does not represent a bias against the female gender.

A2.28 Bidder Requests for Information

Bidder requests for information will be received up to 72 hours prior to Bid Opening.

SECTION A3 - BID DOCUMENTS

CARPINTERIA VALLEY WATER DISTRICT
SANTA BARBARA COUNTY, CALIFORNIA

PROJECT: POTHOLING SERVICES FOR THE CARPINTERIA ADVANCED WATER
PURIFICATION PROJECT

I M P O R T A N T N O T I C E

BID DOCUMENTS:

All bids must be accompanied by the following completed forms:

- CONTRACTOR'S PROPOSAL
- BID SCHEDULE
- BIDDER'S STATEMENT REGARDING INSURANCE COVERAGE
- LIST OF SUBCONTRACTORS AND SUPPLIERS
- PROPOSED EQUIPMENT AND MATERIAL MANUFACTURERS
- BIDDER INFORMATION
- SUPPLEMENTAL BIDDER INFORMATION
- EXPERIENCE STATEMENT
- NON-COLLUSION AFFIDAVIT

Failure to complete, sign (*where required*), and return the above proposal documents with your bid may render it incomplete and non-responsive.

CONTRACTOR'S PROPOSAL

PROJECT: POTHOLING SERVICES FOR THE CARPINTERIA ADVANCED PURIFICATION PROJECT

The undersigned, as bidder, declares that he has examined all of the Contract Documents and specifications contained in the above referenced Project and Bid, and that he will contract with the Board on the form of contract provided therewith to do everything necessary for the fulfillment of this contract at the price and on the terms and conditions therein contained.

The following are included and are to be considered as forming a part of this proposal: (1) Bidding Schedule, (2) Not Used; (3) Bidder's Statement Regarding Insurance Coverage; (4) List of Subcontractors and Suppliers; (5) Non-Collusion Affidavit; (6) Bidder Information, (7) Proposed Equipment and Material Manufacturers, (8) Supplemental Bidder Information, and (9) Experience Statement. We acknowledge that addenda numbers ____ to ____ have been delivered to us and have been examined as part of the Contract Documents.

If our proposal is accepted, we agree to sign the contract form and to furnish the faithful performance and payment bonds (each to be one hundred percent (100%) of the bid amount), and the required evidences of insurance within ten (10) working days after receiving written notice of the award of contract.

We further agree if our proposal is accepted and a contract for the performance of the work is entered into with the Board, to so plan the work and to prosecute it with such diligence that all of the work shall be completed within the time stipulated in SECTION A4 - CONTRACT DOCUMENTS.

Dated: _____

Company Name of Bidder

Bidder's Mailing Address:

Authorized Signature

Title

If Company is a Corporation, provide corporate information per paragraph A2.05

State of Incorporation

BID SCHEDULE

PROJECT: POTHOLING SERVICES FOR THE CARPINTERIA ADVANCED PURIFICATION PROJECT

The cost of all labor, material and equipment necessary for the completion of the work itemized, even though not shown or specified, shall be included in the unit price for each item shown herein. The Board reserves the right to increase or decrease the quantity of any item or omit items as may be necessary and the same shall in no way affect or make void the contract.

The Board reserves the right to reject any and all bids, to waive any informality in a bid, and to make awards in the interest of the Board.

The Contractor will not be reimbursed for work performed for his convenience, or as required to adapt to field conditions, or work outside of that required by the Contract Documents.

The cost of all labor, material and equipment necessary for the completion of the work itemized under this schedule, even though not shown or specified, shall be included in the price for the items shown herein.

BID SCHEDULE (per CD-1 Schedule Table)

Item No.	Est. Qty	Unit	Description	Reference Section	Unit Price	Item Cost
1	1	LS	Mobilization	900-1.A.1		
2	1	LS	Encroachment Permit and Traffic Control Plan	900-1.A.2		
3	6	EA	High Priority Potholes Within Downtown "T" Area	900-1.A.3		
4	14	EA	Other High Priority Potholes	900-1.A.4		
5	2	EA	Medium Priority Potholes Within Downtown "T" Area	900-1.A.5		
6	17	EA	Other Medium Priority Potholes	900-1.A.6		

BID TOTAL \$ _____

Total Bid (in words) _____

The award of contract will be based in part on the lowest bid total from the schedule above. The Contractor must notify the Board in writing prior to construction of any difference between estimated quantities and actual quantities. Payment to the Contractor will be based on the in-place (actual) quantities confirmed during construction by the Board's representative.

The Board reserves the right to increase or decrease the quantity of any item or omit items as may be deemed necessary due to budget limitations or constraints, and the same shall in no way affect or make void the contract, except that appropriate additions or deductions from the contract total price will be made at the prices agreed upon by the Board and the Contractor.

(Company Name of Bidder)

(Authorized Signature)

BIDDER'S STATEMENT REGARDING INSURANCE COVERAGE

PROJECT: POTHOLING SERVICES FOR THE CARPINTERIA ADVANCED PURIFICATION PROJECT

By signing below, bidder hereby certifies that he has reviewed the insurance coverage requirements specified in Section A4. Should he be awarded the contract for the work, Bidder further certifies that he can meet all of these specifications requirements for insurance including insurance coverage of his subcontractors.

Workers' Compensation Insurance: The Contractor shall obtain and maintain workers' compensation insurance required by law covering all of the Contractor's employees on the Work at all times. It shall be the Contractor's responsibility to see that all employees of its subcontractors are equally protected by such insurance either provided by the Contractor or by the subcontractor. The required insurance shall cover any assignee of the Contractor or any subcontractor performing or causing to be performed any work or labor in fulfillment of the provisions of the Contract. The Contractor certifies the following:

I am aware of the provisions of Section 3700 of the Labor Code which require every employer to be insured against liability for workers' compensation or to undertake self-insurance in accordance with the provisions of that code before commencing the performance of the work of this contract.

Bidder

By

Title

Date

LIST OF SUBCONTRACTORS AND SUPPLIERS

PROJECT: POTHOLING SERVICES FOR THE CARPINTERIA ADVANCED PURIFICATION PROJECT

The Contractor is required to furnish the following information in accordance with the provisions of Sections 4100 to 4113, inclusive, of the Public Contract Code of the State of California.

The following is a list of subcontractors and suppliers who will perform work or provide materials of value in excess of one-half percent of the total bid price. No subcontractor shall perform work in excess of the amount specified in Section A2.11, List of Subcontractors, without the written approval of the Board.

Name Under Which Subcontractor is Licensed	License No./ Expiration Date	Address of Office, Mill or Shop	Specific Description of Work Subcontracted or Materials Supplied	Cost of Work

Do not list alternative subcontractors for the same work. ***These representations are being made under penalty of perjury.***

Contractor: _____
By: _____
Title: _____

PROPOSED EQUIPMENT AND MATERIAL MANUFACTURERS

PROJECT: POTHOLING SERVICES FOR THE CARPINTERIA ADVANCED PURIFICATION PROJECT

The Bidder shall indicate in the space provided below the name of the manufacturer of the listed equipment, and supplier of the listed material, proposed to be furnished under the contract. Awarding of a contract based on this bid will not imply approval by the Owner of the manufacturers or suppliers listed by the Bidder. No substitution will be permitted after award of contract except upon written approval of the Owner.

Equipment/Materials

Manufacturer

Supplier

Contractor

Authorized signature

BIDDER INFORMATION

PROJECT: POTHOLING SERVICES FOR THE CARPINTERIA ADVANCED PURIFICATION PROJECT

BIDDER and SUBCONTRACTORS for work exceeding 10% of the contract price certify that the following information is true and correct (add additional pages as necessary):

Name _____ of _____ Proposer:

Business _____ Address:

Telephone: _____ FAX: _____ E-mail: _____

Contractor's License No.: _____ Date Issued: _____ Expiration _____ Date: _____

The following are the names, titles, addresses, and phone numbers of all individuals, firm members, partners, joint venturers, and/or corporate officers having a principal interest in this proposal: (Name/Title/Address/Telephone #)

Any voluntary or involuntary bankruptcy judgments against any principal having an interest in this proposal are as follows: (Type of Judgment / Date)

All current and prior DBA's, alias, and/or fictitious business names for any principal having an interest in this proposal are as follows: (Principal / DBA's / Applicable Dates)

Prior Disqualification

Has your firm ever been disqualified, suspended, terminated, withdrawn, rendered ineligible and/or precluded, either voluntarily or involuntarily, from soliciting, bidding on or applying for and/or performing any services or work for any City, County, Public or Private Contracting entity, and/or being placed on probation (i.e., a process or period of testing or observing the character or abilities of your firm's work for a certain period of time) while performing any services of work for any City, County, Public or Private Contracting entity? Yes / No _____. If yes, provide the following information. (If more than once, use separate sheets):

Date: _____ Entity: _____

Location: _____

Reason:

Provide Status and any Supplemental Statement:

Has your firm been reinstated or re-qualified by this entity, including through the lifting of any suspension, ineligibility or disqualification, the firm's re-qualification, the expiration and/or satisfaction of any agreement or sanction, and/or the expiration of any probationary period? Yes / No _____

Violations of Federal or State Law

Has your firm or its officers been found in violation of, or assessed any penalties by any local (municipal or county), State or Federal AGENCY (including but not limited to the Department of Industrial Relations for the State of California) for noncompliance, violations of Federal or State labor laws and/or business or licensing regulations, within the past five (5) years relating to your construction projects?

Yes / No: _____ Federal / _____ State/ _____ Local:

If "yes", identify and describe, (including status):

Have the penalties been paid? Yes / No: _____

B. Does your firm or its officers have any ongoing investigations by any local (municipal or county), State or Federal AGENCY (including but not limited to the Department of Industrial Relations for the State of California) regarding violations of the State Labor Code, California Business and Professions Code or State Licensing laws?

Yes / No: _____ Codes / Laws: _____ Section / _____ Article:

If "yes", identify and describe (including status):

I declare under penalty of perjury under the laws of the State of California that all of the representations made in this **BIDDER INFORMATION** are true and correct. Executed this _____ day of _____, 20____, at _____, California.

AUTHORIZED SIGNATURE: _____

TITLE: _____

SUPPLEMENTAL BIDDER INFORMATION

PROJECT: POTHOLING SERVICES FOR THE CARPINTERIA ADVANCED PURIFICATION PROJECT

The following supplemental questions are specific to this project and shall be used by the Board in the evaluation of a contractor. BIDDER/SUBCONTRACTORS certify that the following information is true and correct (CVWD may verify all information):

Questions:

1. Describe experience with similar Construction

Project Location & Description of Work and Date of Project	Project Value
1.	
2.	
3	
4	
5	

2. Schedule is critical on this project. Describe manpower and equipment resources available beyond that which is anticipated will do the job (contingency capabilities). _____

3. Describe recent experience where you have completed a schedule-critical project with a very limited construction window?

EXPERIENCE STATEMENT

PROJECT: POTHOLING SERVICES FOR THE CARPINTERIA ADVANCED PURIFICATION PROJECT

Pursuant to A2.10 QUALIFICATION, LICENSE AND EXPERIENCE OF PROPOSERS, following is a record of the Bidder's and any Subcontractor's (performing more than 10% of the total bid) experience in construction of a type similar in magnitude and character to that contemplated under this contract. Included in this section should be a complete list of references for similar projects in terms of scope of work, value of work, and time constraints. The Contractor must demonstrate that he/she has experience with this type of project and can manage this project effectively. If necessary, additional numbered pages can be attached to this page. The Contractor must be properly licensed to perform the work in this project as determined by the State Contractor's License Board. CVWD may contact listed references. A minimum of 3 projects shall be listed for the Bidder and each Subcontractor that have been completed in the last five years.

Project Title: _____ Client: _____

Date: _____ Project Value: _____ Contact: _____ Tel #: _____

Description: _____

Subject to Federal Labor Standards: _____ Yes _____ No

Project Title: _____ Client: _____

Date: _____ Project Value: _____ Contact: _____ Tel #: _____

Description: _____

Subject to Federal Labor Standards: _____ Yes _____ No

Project Title: _____ Client: _____

Date: _____ Project Value: _____ Contact: _____ Tel #: _____

Description: _____

Subject to Federal Labor Standards: _____ Yes _____ No

I declare under penalty of perjury under the laws of the State of California that all of the representations made in THIS EXPERIENCE STATEMENT are true and correct. Executed this _____ day of _____, 20____, at _____, California.

AUTHORIZED SIGNATURE: _____

TITLE: _____

NON-COLLUSION AFFIDAVIT

PROJECT: POTHOLING SERVICES FOR THE CARPINTERIA ADVANCED PURIFICATION PROJECT

State of California)
County of Santa Barbara) ss.

The undersigned declares:

_____, being first duly sworn, deposes and says that he or she is _____ of _____, the party making the foregoing bid, that the bid is not made in the interest of, or on behalf of, any undisclosed person, partnership, company, association, organization, or corporation; that the bid is genuine and not collusive or sham; that the bidder has not directly or indirectly induced or solicited any other bidder to put in a false or sham bid, and has not directly or indirectly, colluded, conspired, connived, or agreed with any bidder or anyone else to put in a sham bid, or that anyone shall refrain from bidding; that the bidder has not in any manner, directly or indirectly, sought by agreement, communication, or conference with anyone to fix the bid price of the bidder or any other bidder, or to fix any overhead, profit, or cost element of the bid price, or of that of any other bidder, or to secure any advantage against the public body awarding the contract of anyone interested in the proposed contract; that all statements contained in the bid are true; and, further, that the bidder has not, directly or indirectly, submitted his or her bid price or any breakdown thereof, or the contents thereof, or divulged information or data relative thereto, or paid, and will not pay, any fee to any corporation, partnership, company association, organization, bid depository, or to any member or agent thereof to effectuate a collusive or sham bid.

Any person executing this declaration on behalf of a bidder that is a corporation, partnership, joint venture, limited liability company, limited liability partnership, or any other entity, hereby represents that he or she has full power to execute, and does execute, this declaration on behalf of the bidder.

I declare under penalty of perjury that the foregoing is true and correct. Executed on _____, 20__, at _____, California.

Signature

Subscribed and sworn to before me on _____.
(date)

[NOTARY SEAL]

Signature of Notary Public

SECTION A4 - CONTRACT DOCUMENTS

CARPINTERIA VALLEY WATER DISTRICT
SANTA BARBARA COUNTY, CALIFORNIA

PROJECT: POTHOLING SERVICES FOR THE CARPINTERIA ADVANCED PURIFICATION
PROJECT

- CONTRACT AGREEMENT
- PAYMENT BOND
- PERFORMANCE BOND
- INSURANCE REQUIREMENTS FOR CONTRACTORS

CONTRACT AGREEMENT
FOR THE
POTHOLING SERVICES FOR THE CARPINTERIA ADVANCED PURIFICATION PROJECT
FOR THE CARPINTERIA VALLEY WATER DISTRICT
SANTA BARBARA COUNTY, CALIFORNIA

Contract Price \$_____

THIS AGREEMENT made this _____ day of _____, 20__, by and between the Carpinteria Valley Water District, a public entity, organized and existing in the County of Santa Barbara, under and by virtue of the laws of the State of California, hereinafter designated as Board, and _____, hereinafter designated as Contractor.

The Board and the Contractor, in consideration of the mutual promises, covenants and conditions hereinafter set forth, agree as follows:

ARTICLE 1 - THE WORK

In consideration of payments and agreements to be made by the Board, the Contractor shall perform and complete in a prompt and workmanlike manner the work in the Board's Contract Documents entitled:

POTHOLING SERVICES FOR THE CARPINTERIA ADVANCED PURIFICATION PROJECT

The Work is generally described as follows:

Potholing at various locations in the City of Carpinteria, preparing traffic control plans, obtaining permits from the City of Carpinteria, documenting corresponding underground utilities, backfilling potholes with a slurry, and restoring pavement.

The Contractor shall perform all work in accordance with, and meet all requirements of, the Contract Documents, and shall furnish at his own expense all labor, materials, equipment, tools, transportation, and services necessary therefore, except for such materials, equipment and services (if any) as may be set forth in the Contract Documents to be furnished by the Board.

ARTICLE 2 - COMMENCEMENT AND COMPLETION; LIQUIDATED DAMAGES;

The Work to be performed under this Contract shall commence on the date specified in the Notice to Proceed by the Board and the Work shall be fully completed within Thirty (30) Working Days. The Board will issue Notice to Proceed within 10 days of execution of the Contract which will follow acceptance of Contractor's bonds and insurance certificates.

The Board and the Contractor recognize that time is of the essence of this Agreement and that the Board will suffer financial loss if the Work is not completed within the time specified herein, plus any extensions thereof allowed in accordance with Section B - General Provisions Modifications, including Paragraph 6-9. The parties also recognize the delays, expense and difficulties involved in proving in a legal proceeding the actual loss suffered by the Board if the Work is not completed on time. Accordingly, instead of requiring any such proof, the Board and

the Contractor agree that as liquidated damages (but not as penalty) the Contractor shall pay the Board the sum of \$1,000.00 for each calendar day that expires after the time specified herein. The parties agree that assessment of liquidated damages is valid in accordance with California Government Code Section 53069.85.

Contractor activities shall not interrupt, impede, or interfere with the SCC operations. The Board and the Contractor recognize that disruption of SCC operations will result in loss of water service that may pose a risk to public health, and that may result in regulatory fines or other sanctions. The parties also recognize the delays, expense and difficulties involved in proving in a legal proceeding the actual loss suffered by the Board due to a disruption in service. Accordingly, instead of requiring any such proof, the Board and the Contractor agree that as liquidated damages (but not as penalty) the Contractor shall pay the Board the sum of \$500 for each hour or portion thereof that expires after the disruption. The parties agree that assessment of liquidated damages is valid in accordance with California Government Code Section 53069.85.

Contractor shall not interrupt service to District Customers outside the hours stipulated on the plans. In the event of such an unauthorized disruption of SCC operations, CVWD and the Contractor agree that as liquidated damages (but not as penalty) the Contractor shall pay CVWD the sum of \$250 for each hour or portion thereof that expires after the disruption.

ARTICLE 3 - CONTRACT PRICE

The Board will pay the Contractor for the completion of the Work in accordance with the Contract Documents in current funds the Contract Price(s) as set forth above.

ARTICLE 4 - THE CONTRACT DOCUMENTS

The Contract Documents consist of:

- Notice and Invitation to Submit Sealed Construction Cost Proposal (Bid)
- Instructions to Bidders
- Contractor's Proposal
- Bid Schedule
- Bidder's Statement Regarding Insurance Coverage
- List of Subcontractors and Suppliers
- Proposed Equipment and Materials Manufacturers
- Bidder Information
- Supplemental Bidder Information
- Experience Statement
- Non-Collusion Affidavit
- Contract Agreement
- Payment Bond
- Performance Bond
- Insurance Requirements for Contractors
- Standard Specifications (SSPWC)
- Modifications to Standard Specifications (General Provisions Modifications)
- Special Provisions – Technical
- Attachments

ARTICLE 5 - PAYMENT PROCEDURES

The Contractor shall submit applications for Payment for each calendar month in accordance with Section 9-7, Measurement and Payment as modified herein of the Standard Specifications (SSPWC). The payment application shall be submitted in spread sheet format acceptable to CVWD. Applications for Payment will be processed by CVWD as provided in the Standard Specifications.

ARTICLE 6 - NOTICES

Whenever any provision of the Contract Documents requires the giving of written notice, it shall be deemed to have been validly given if delivered in person to the individual or to a member of the firm or to an officer of the corporation for whom it is intended, or if delivered at or sent by registered or certified mail, postage prepaid, to the last business address known to the giver of the Notice.

ARTICLE 7 - NO ASSIGNMENT

No assignment by a party hereto of any rights under or interests in the Contract Documents will be binding on another party hereto without the written consent of the party sought to be bound; and specifically, but without limitation, monies that may become due and monies that are due may not be assigned without such consent (except to the extent that the effect of this restriction may be limited by law), and, unless specifically stated to the contrary in any written consent to an assignment, no assignment will release or discharge the assignor from any duty or responsibility under the Contract Documents. Any assignment of money shall be subject to all proper withholdings in favor of Board and to all deductions provided for in the Contract Documents. All money withheld, whether assigned or not, shall be subject to being used by the Board for completion of the work, should the Contractor be in default.

The Board and the Contractor each binds itself, and its partners, officers, directors, employees, successors, assigns, and legal representatives to the other party hereto, and their partners, officers, directors, employees, successors, assigns, and legal representatives in respect of all covenants, agreements, and obligations contained in the Contract Documents.

ARTICLE 8 - PREVAILING WAGES/LABOR CODE COMPLIANCE

The general prevailing rates of per diem wages and general prevailing rate for holiday and overtime work in the locality in which the work is to be performed have been determined by the Board. The general prevailing rates of per diem wages are hereby incorporated herein and made a part hereof. The Contractor agrees that he, or any subcontractor under him, will pay not less than the foregoing specified prevailing rates of wages to all workmen employed in the execution of the Contract.

Any contractor who is awarded a public works project and intends to use a craft or classification not shown on the general prevailing wage determinations, may be required to pay the wage rate of that craft or classification most closely related to it as shown in the general determinations effective at the time of the call for bids.

The Contractor further acknowledges that the referenced provisions of the California Labor Code

are applicable to this project. Contractor covenants that it will comply with such provisions. These provisions include, but are not limited to, the levying of penalties for failure to pay prevailing wages (Labor Code Section 1775) or for workmen who are required or permitted to work more than eight hours in one calendar day and forty hours in one calendar week in violation of the Labor Code (Labor Code Section 1813); and the keeping and furnishing of accurate and certified payroll records (Labor Code Section 1776).

ARTICLE 9 - INDEMNITY OBLIGATIONS

- A. Promptly upon execution of the Contract, Contractor specifically obligates itself and agrees to protect, hold free and harmless, investigate, defend and indemnify the CVWD, and their consultants, and each of their member entities (“members”), officers, trustees, directors, officials, employees and agents, from and against any and all liability, penalties, costs, losses, damages, expenses, causes of action, claims or judgments, including without limitation attorneys’ fees and costs of litigation, which arise out of or are in any way connected with Contractor’s or its subcontractors’ or suppliers’ performance of work under this Contract or failure to comply with any of the obligations contained in the Contract. To the fullest extent legally permissible, this indemnity, defense and hold harmless obligation of Contractor shall apply to any and all acts or omissions, whether active or passive, on the part of the Contractor or its agents, employees, representatives, or any subcontractor’s agents, employees, and representatives, resulting in claim or liability (including but not limited to death or bodily injury to, or damage to property of, Contractor or any subcontractor, person, firm, corporation, or supplier employed by the Contractor upon or in connection with the Work, either directly or by indirect contact), irrespective of whether or not any acts or omissions of any of the parties to be indemnified hereunder may also have been a contributing factor to the liability, except such loss or damage which was caused by the active negligence, sole negligence, or willful misconduct of the indemnitees. This provision shall be construed in accordance with California Civil Code Section 2782 et seq. and notwithstanding any provision to the contrary in Paragraph 5-4 of the Standard Specifications.
- B. In any and all claims against the Board, and their consultants, and each of their members, trustees, directors, officers, employees and agents by any employee of the Contractor, any subcontractor, anyone directly or indirectly employed by any of them, or anyone for whose acts any of them may be liable, the indemnification obligation under this Section shall not be limited in any way by any limitation of the amount or type of damages, compensation or benefits payable by or for the Contractor or any subcontractor under Worker’s Compensation statutes, disability benefit statutes or other employee benefit statutes, or other insurance policies furnished by Contractor as required herein.
- C. Contractor’s indemnity obligations within this Article 9 shall survive the expiration or completion of this agreement.

ARTICLE 10 – PAYMENT AND PERFORMANCE BONDS

Contractor as part of its Contract Price, and prior to commencement of work, shall supply to the Board payment and performance bonds (each in the amount of 100% of the Contract Price). The

payment bond shall meet all requirements of Civil Code Section 9550 and 9554 and shall be in a form satisfactory to the Board. The performance bond shall be in the form provided in these Contract Documents or as otherwise acceptable to the Board. The bonds provided by the Contractor must be issued by a California admitted surety insurer licensed to do business in the State of California (as set forth in California Code of Civil Procedure Section 995.010 et. seq.) and with a current A. M. Best's rating no less than A:VII or equivalent or as otherwise approved by Board.

ARTICLE 11 – EARLY TERMINATION OF CONTRACT

If the Board elects to terminate the Contract prior to completion of the work, then notwithstanding any other provisions in these Contract Documents, such termination and the total compensation payable to the Contractor shall be governed by the following:

(1) The General Manager will issue Contractor a written notice specifying that the Contract is terminated. Except as otherwise directed in writing by the General Manager, the Contractor shall:

- A. Stop all work under the Contract except that specifically directed to be completed prior to acceptance.
- B. Notify all of Contractor's subcontractors and suppliers that the Contract is being terminated and that their contracts and orders are not to be further performed unless otherwise authorized in writing by the Board.
- C. Perform work the Engineer deems necessary to secure the Project for termination.
- D. Remove equipment and plant from the site of the Work, as directed.
- E. Take action that is necessary to protect materials from damage.
- F. Provide the General Manager with an inventory list of all materials previously produced, purchased or ordered from suppliers for use in the Work and not yet used in the Work, including its storage location, and such other information as General Manager may request.
- G. Dispose of materials not yet used in the Work, as directed by General Manager. Contractor shall provide the Board with good title to all materials purchased by the Board hereunder (including materials for which partial payment has been made), and with bills of sale or other indicia of title for the materials.
- H. Subject to the General Manager's prior written approval, settle all outstanding liabilities and claims arising out of subcontracts or orders for materials terminated hereunder. To the extent directed by the General Manager, the Contractor shall assign to the Board all the right, title and interest of the Contractor under such subcontracts or orders referenced herein.
- I. Furnish the General Manager with any documentation required to be furnished by the Contractor in accordance with the Contract Documents.
- J. Take any other actions required by General Manager.

(2) Termination of the Contract shall not relieve any surety of its obligations for just claims arising out of the work performed.

(3) The total compensation to be paid to Contractor shall be determined by the General Manager on the basis of the following:

- A. The reasonable cost to Contractor, without profit, for all work performed under the Contract, including mobilization, demobilization and work done to secure the Project for termination. In determining the reasonable cost, deductions will be made for the cost of materials to be retained by the Contractor, amounts realized by sale of the materials, and for other appropriate credits against the cost of the Work. When in the General Manager's opinion, the cost of a contract item of work is excessively high due to costs to remedy or replace defective or rejected work, the reasonable cost to be allowed will be the estimated reasonable cost of performing that work in compliance with the requirements of the plans and specifications and the excessive actual cost shall be disallowed.
- B. A reasonable allowance for profit on the cost of the work as determined pursuant to subparagraph (A) herein, provided that the Contractor establishes to the satisfaction of the General Manager that it is reasonably probable that the Contractor would have made a profit had the Contract been completed and provided further that the profit allowed shall in no event exceed four percent (4%) of the cost.
- C. The reasonable cost to the contractor of handling material returned to vendor(s), delivered to the site of the Work or disposed of as directed by the General Manager.
- D. A reasonable allowance for the Contractor's administrative costs in determining the amount payable due to the termination of the Contract.

(4) All records of the Contractor and its subcontractors and suppliers necessary to determine compensation in accordance with these provisions shall be retained and open to inspection or audit by representatives of the Board at all times after issuance of the notice that the Contract will be terminated and for a period of three (3) years thereafter.

(5) After its acceptance of the Work, the Board may make payments on the basis of interim estimates pending issuance of the final estimate when, in the opinion of the General Manager, the amount thus paid, together with all amounts previously paid or allowed, will not result in total compensation in excess of that to which the Contractor will be entitled. All payments, including payment of the final estimate, shall be subject to deductions for prior payments and amounts, if any, to be kept or retained under the provisions of the contract.

These provisions shall be included in any subcontracts.

ARTICLE 12 – LAWS, REGULATIONS AND PERMITS

Contractor, at its expense, shall give all notices and (unless otherwise provided herein) obtain all permits for the work required by law, and shall comply with all applicable federal, state and local laws, ordinances, rules, regulations, orders and permit conditions pertaining to the conduct of the work, including but not limited to those regarding protection of the environment. Contractor shall

be liable for all violations of the law in connection with work furnished by Contractor. If Contractor observes that any drawings or specifications are at variance with any law or ordinance, rule or regulation, he/she shall promptly notify the Board's authorized representative in writing and any necessary changes shall be made by written instruction or change order. If Contractor performs any work knowing it to be contrary to such laws, ordinances, rules or regulations and without giving notice to the Board's authorized representative, Contractor shall bear all costs arising therefrom.

ARTICLE 13 – SAFETY

Contractor shall execute and maintain its work so as to avoid injury or damage to any person or property. Contractor shall comply with the requirements of the specifications relating to safety measures applicable in particular operations or kinds of work. Contractor shall designate, in writing, a responsible representative at the worksite whose duty shall be the prevention of accidents, and the maintenance and supervision of safety precautions and programs. This person shall be Contractor's Construction Manager unless otherwise designated in writing by Contractor.

In carrying out its work, Contractor shall at all times exercise all necessary precautions for the safety of employees appropriate to the nature of the work and the conditions under which the work is to be performed, and shall comply with all applicable federal, state and local statutory and regulatory requirements including California Department of Industrial Relations (Cal/OSHA) regulations; and the U.S. Department of Transportation Omnibus Transportation Employee Testing Act. Safety precautions, as applicable, shall include but shall not be limited to: adequate life protection and lifesaving equipment; first aid; adequate illumination; instructions in accident prevention for all employees, such as the use of machinery guards, safe walkways, scaffolds, fall protection, ladders, bridges, gang planks, confined space procedures, trenching and shoring, and other safety devices; equipment and wearing apparel as are necessary or lawfully required to prevent accidents, injuries, or illnesses; and adequate facilities for the proper inspection and maintenance of all safety measures. Contractor shall submit its Injury Illness Prevention Plan (IIPP) to the Board for approval prior to commencement of the Work.

If applicable, in accordance with Section 6705 of the California Labor Code, Contractor shall submit to CVWD specific plans to show details of provisions for worker protection from caving ground during excavations of trenches of five feet or more in depth. The excavation/trench safety plan shall be submitted to and accepted by CVWD prior to starting excavation. The trench safety plan shall have details showing the design of shoring, bracing, sloping or other provisions to be made for worker protection from the hazard of caving ground. If such a plan varies from the shoring system standards established by the Construction Safety Orders of the California Department of Industrial Relations (Cal/OSHA), the plan shall be prepared by a California registered civil or structural engineer. As part of the plan, a note shall be included stating that the registered civil or structural engineer certifies that the plan complies with the Cal/OSHA Construction Safety Orders, or that the registered civil or structural engineer certifies that the plan is not less effective than the shoring, bracing, sloping or other provisions of the Safety Orders. In no event shall Contractor use a shoring, sloping, or protective system less effective than that required by said Construction Safety Orders. Submission of the plan in no way relieves Contractor of the requirement to maintain safety in all areas. If excavations or trench work requiring a Cal/OSHA permit are to be undertaken, Contractor shall submit his/her permit with the excavation/trench work safety plan to CVWD before work begins.

If applicable, Contractor shall also comply with the provisions of California Public Contract Code Section 7104, which pertains to the digging of trenches or other excavations extending deeper than four feet below the surface and the discovery of hazardous waste or subsurface or unknown latent physical conditions differing materially from those ordinarily encountered. The provisions of Section 7104 are incorporated by reference herein as if set forth in full.

Pursuant to California Labor Code Section 6708, each Contractor and subcontractor shall maintain or make available adequate emergency first aid treatment for its employees, agents and representatives, sufficient to comply with the Federal Occupational Safety & Health Act (P.L. 91-596; OSHA). The names and telephone numbers of at least two medical doctors practicing in the vicinity and the telephone number of the local ambulance service shall be prominently displayed adjacent to telephones.

Safety Measures and Public Convenience - Contractor shall provide for the protection of all persons and property as herein specified. Attention is called to "Construction Safety Orders: and General Safety Orders" of the California State Industrial Accident Commission to which Contractor is required by law to conform.

ARTICLE 14 – NO WAIVER

No failure by CVWD in asserting any of its rights or remedies as to any default of Contractor shall operate as a waiver of the default, or any subsequent or other default by Contractor, or of any of the Board's rights or remedies. No such delay shall deprive CVWD of its right to institute and maintain any actions or proceedings which may be necessary to protect, assert, or enforce any rights or remedies arising out of this Agreement or the performance thereof.

ARTICLE 15 - SEVERABILITY

If any provision of these Contract Documents shall be held void or unenforceable, such determination shall not affect the remaining provisions thereof, which shall continue in valid force and effect.

ARTICLE 16 - INCORPORATION OF APPLICABLE STATUTORY PROVISIONS

The parties agree that all provisions of law which apply to this Contract Agreement form a part of this Contract Agreement, are incorporated by reference herein as if set forth in full, and that Contractor shall comply with all such provisions.

ARTICLE 17 - CHANGES TO LAW

If any changes or modifications to applicable laws governing the Work are not specifically reflected herein, they are hereby deemed adopted and incorporated by reference herein, and shall supersede any provisions to the contrary.

ARTICLE 18 - VENUE

Any proceedings arising out of dispute(s) between the Board and the Contractor as to any provision(s) of this Contract Agreement shall occur within the County of Santa Barbara, State of California.

ARTICLE 19 – CONTRACTOR RESPONSIBILITY FOR PENALTIES/SANCTIONS/COSTS

Contractor shall be responsible for penalties assessed or levied on Contractor or CVWD, and costs incurred by CVWD, as a result of the Contractor's failure to comply with the provisions in this Contract, including, but not limited to, compliance with the applicable provisions of federal, state and local laws, regulations, orders and permit requirements as set forth therein. Penalties as used in this section shall include fines, penalties and damages, whether proposed, assessed, or levied against CVWD or Contractor, including those levied by governmental agencies or as a result of citizen suits. Penalties shall also include payments made or costs incurred in settlement for alleged violations of federal, state and local laws, regulations, orders and permit requirements. Costs incurred could include sums spent instead of penalties, in mitigation or to remediate or correct violations.

IN WITNESS WHEREOF, the BOARD and the CONTRACTOR have caused this Agreement to be executed the day and year first written above.

CARPINTERIA VALLEY
WATER DISTRICT

CONTRACTOR

By: _____

By: _____

District Board President

Title: _____

License No.: _____

ATTEST:

ATTEST:

Secretary to the Board of Directors

APPROVED AS TO FORM:

AGENT FOR SERVICE OF PROCESS:

By _____
Attorneys for Board

Principal:

Bond No.: _____

_____ Bond Type: _____

Bond Amount: _____

**POTHOLING SERVICES FOR THE CARPINTERIA ADVANCED PURIFICATION PROJECT
PAYMENT BOND**

[Civil Code Sections 3247-3248]

This Payment (Labor and Materials) Bond is tendered to the CARPINTERIA VALLEY WATER DISTRICT ("Board") in conjunction with "POTHOLING SERVICES FOR THE CARPINTERIA ADVANCED PURIFICATION PROJECT" (Project) set forth above.

We, the Principal _____ and _____ a Surety Corporation, organized and existing under and by virtues of the laws of the State of _____ and duly authorized to transact business within the State of California as a surety, are held and firmly bound unto the Board, for the use and benefit of itself and any and all persons, companies, or corporations who perform work or labor or furnish materials, provisions, or other supplies used in, upon, for or about the performance of the above-described work, or who rent or lease persons or machinery for said work to be done, in the sum of _____ (\$ _____) in lawful money of the United States of America, to be paid to such persons, companies or corporations, for which payment, well and truly to be made, we bind ourselves, our heirs, executors, administrators, successors and assigns, jointly and severally, firmly by these presents.

The Board has awarded Principal a contract for the above-described project and the Principal is required by the terms of the contract to furnish a bond for materialmen and laborers involved in the Project; and thus, if said Principal, or any subcontractor or contractors, fail to pay any persons named in Civil Code Section 3181 or for any materials, provisions, provender, or other supplies, or persons or machinery used in, upon, for or about the performance of the work contracted to be done, or for any work or labor thereon of any kind or for amounts due under the Unemployment Insurance Code with respect to such work or labor, or any amounts required to be deducted, withheld, and paid over to the Employment Development Department from the wages of employees of the Contractor and its subcontractors pursuant to Unemployment Insurance Code Section 13020, the Surety will pay the same up to an amount not exceeding the sum specified in this bond and in case suit is brought upon this bond, additional, reasonable attorneys' fees to be fixed by the court. This bond shall inure to the benefit of any and all persons entitled to file claims under California Civil Code Section 3181, so as to give a right of action to such persons or his assigns in any suit brought upon this bond.

The Surety hereby stipulates and agrees that no change, extension of time, alteration or addition to the terms of the Contract or to the Project or work to be performed hereunder, or the specifications and drawings that accompany same, shall in any way affect its obligations on this bond; and it does hereby waive notice of any such change, extension of time, alterations or addition to the terms of the Contract, to the work or Project, or to the drawings and specifications.

Whenever the Principal shall be, and declared by the Board to be in default under the above Agreement, the Surety shall promptly remedy the default, or shall promptly pay the amount of the

bond herein.

For the satisfactory completion of this Project and the Contract hereunder, the above obligations shall hold good for a period of one (1) year after the completion of the Project and its acceptance by the Board, during which time if Principal shall fail to make full, complete and satisfactory repair and replacements and totally protect the Board from loss or damage made evident during the period of one (1) year from the date of acceptance of the work and resulting from or caused by defective materials or faulty workmanship, the above obligations shall remain in full force and effect. The obligation of the Surety hereunder shall continue so long as any obligation of the Principal remains.

IN WITNESS WHEREOF, this Payment Bond is duly executed by the Principal and Surety above-named on _____, 20____.

PRINCIPAL:

*SURETY:

NAME OF PRINCIPAL

NAME OF SURETY

SIGNATURE

SIGNATURE

TYPED NAME AND TITLE

TYPED NAME AND TITLE

ADDRESS

ADDRESS

CITY, STATE, ZIP

CITY, STATE, ZIP

TELEPHONE

TELEPHONE

*Power of Attorney Must Be Attached.

Subscribed and sworn to this _____ day of _____, 20__.

NOTARY PUBLIC _____ [SEAL]

Principal:

Bond No.: _____

Bond Type: _____

Bond Amount: _____

POTHOLING SERVICES FOR THE CARPINTERIA ADVANCED PURIFICATION PROJECT

PERFORMANCE BOND

This Performance Bond is tendered to the CARPINTERIA VALLEY WATER DISTRICT (“Board”) in conjunction with “POTHOLING SERVICES FOR THE CARPINTERIA ADVANCED PURIFICATION PROJECT” (Project) as set forth above.

We, the Principal _____ and _____, a Surety Corporation, organizing existing under and by virtue of the laws of the State of _____ and duly authorized to transact business within the State of California as a surety, are held and firmly bound unto the Board the sum of _____ (\$ _____) lawful money of the United States of America, for the payment of which sum we bind ourselves, our heirs, executors, administrators, and successors, jointly and severally, firmly by these presents.

The condition of this obligation is such that if the above-bound Principal, his or its heirs, executors, administrators successors or assigns shall abide by, keep and perform the covenants, conditions, requirements, obligations, and provisions of the aforescribed Project and/or Contract, any alterations thereof, or any regulations or laws pertaining thereto on his or their part to be kept and performed at the time in the manner therein specified and if they also indemnify and hold the Board, and its members, officers, agents, employees harmless from all liability, costs, losses, expenses, and attorneys' fees thereon, then this obligation shall become null and void; but otherwise, it shall be and remain in full force and effect.

The Surety hereby stipulates and agrees that no change, extension of time, alteration or addition to the terms of the Contract or to the Project or work to be performed hereunder, or the specifications and drawings that accompany same, shall in any way affect its obligations on this bond; and it does hereby waive notice of any such change, extension of time, alterations or addition to the terms of the Contract, to the work or Project, or to the drawings and specifications.

Whenever the Principal shall be, and declared by the Board to be in default under the above agreement, the Surety shall promptly remedy the default, or shall promptly pay the amount of the bond herein.

For the satisfactory completion of this Project and the Contract hereunder, the above obligations shall hold good for a period of one (1) year after the completion of the Project and its acceptance by the Board, during which time if Principal shall fail to make full, complete and satisfactory repair and replacements and totally protect the Board from loss or damage made evident during the period of one (1) year from the date of acceptance of the work and resulting from or caused by defective materials or faulty workmanship, the above obligations shall remain in full force and effect. The obligation of the Surety hereunder shall continue so long as any obligation of the Principal remains.

IN WITNESS WHEREOF, this Performance Bond is duly executed by the Principal and Surety above-named on _____, 20____.

PRINCIPAL:

*SURETY:

NAME OF PRINCIPAL

NAME OF SURETY

SIGNATURE

SIGNATURE

TYPED NAME AND TITLE

TYPED NAME AND TITLE

ADDRESS

ADDRESS

CITY, STATE, ZIP

CITY, STATE, ZIP

TELEPHONE

TELEPHONE

*Power of Attorney Must Be Attached.

Subscribed and sworn to this _____ day of _____, 20__.

NOTARY PUBLIC _____ [SEAL]

INSURANCE REQUIREMENTS FOR CONTRACTORS

Contractor shall procure and maintain for the duration of the contract insurance against claims for injuries to persons or damages to property which may arise from or in connection with the performance of the work hereunder by the Contractor, his agents, representatives, employees or subcontractors. The cost of such insurance shall be included in the Contractor's bid.

Minimum Scope of Insurance

Coverage shall be at least as broad as:

1. Insurance Services Office Commercial General Liability coverage (occurrence form CG 0001).
2. Insurance Services Office form number CA 0001 (Ed. 1/87) covering Automobile Liability, Code I (any auto).
3. Employer's Liability insurance.

Workers' Compensation Insurance: The Contractor shall obtain and maintain workers' compensation insurance required by state law covering all of the Contractor's employees on the Work at all times. It shall be the Contractor's responsibility to see that all employees of its subcontractors are equally protected by such insurance either provided by the Contractor or by the subcontractor. The required insurance shall cover any assignee of the Contractor or any subcontractor performing or causing to be performed any work or labor in fulfillment of the provisions of the Contract. The Contractor certifies the following:

I am aware of the provisions of Section 3700 of the Labor Code which require every employer to be insured against liability for workers' compensation or to undertake self-insurance in accordance with the provisions of that code before commencing the performance of the work of this contract.

Minimum Limits of Insurance

Contractor shall maintain limits not less than:

1. General Liability: \$2,000,000 per occurrence for bodily injury, personal injury and property damage. If Commercial General Liability Insurance or other form with a general aggregate limit is used, either the general aggregate limit shall apply separately to this project/location or the general aggregate limit shall be twice the required occurrence limit.
2. Automobile Liability: \$2,000,000 per accident for bodily injury and property damage.
3. Workers Compensation: Statutory Limit
4. Employers Liability: \$2,000,000 per accident for bodily injury or disease.

Deductibles and Self-Insured Retentions

Any deductibles or self-insured retentions must be declared to and approved by the Board. At the option of the Board, either: the insurer shall reduce or eliminate such deductibles or self-insured retentions), the Board, its members and its officers, consultants, officials and employees and volunteers, or the Contractor shall procure a bond guaranteeing payment of losses and related investigations, claim administration and defense expenses.

Other Insurance Provisions

The general liability and automobile liability policies are to contain, or be endorsed to contain, the following provisions:

1. CVWD, Board and its members, officers, officials, employees, agents, volunteers, and Consultants shall be covered as insureds (via ISO endorsement CG 2010, CG 2033 or insurer's equivalent for general liability coverage) as respects: liability arising out of activities performed by or on behalf of the Contractor; products and completed operations of the Contractor; premises owned, occupied or used by the Contractor; or automobiles owned, leased, hired or borrowed by the Contractor. The coverage shall contain no special limitations on the scope of protection afforded to Reclamation, Board and their members, Consultants, officers, officials, employees, and agents or volunteers.
2. For any claims related to this project, the Contractor's insurance coverage shall be primary insurance as respects CVWD, Board and their members, officers, officials, employees, and agents, volunteers, and Consultants. Any insurance or self-insurance maintained by Reclamation, Board and their members, officers, officials, employees, and agents or volunteers shall be excess of the Contractor's insurance and shall not contribute with it.
3. Any failure to comply with reporting or other provisions of the policies including breaches of warranties shall not affect coverage provided to CVWD, Board and their members, officers, officials, employees, and agents, volunteers and Consultants.
4. The Contractor's insurance shall apply separately to each insured against whom claim is made or suit is brought, except with respect to the limits of the insurer's liability.
5. Each insurance policy required by this clause shall be endorsed to state that coverage shall not be suspended, voided, canceled by either party, reduced in coverage or in limits except after thirty (30) days' written notice by certified mail, return receipt requested, has been given to the Board.

Acceptability of Insurers

Insurance is to be placed with insurers with a current A.M. Best's rating of no less than A:VII or equivalent or as otherwise approved by Board.

Verification of Coverage

Contractor shall furnish the Board with original endorsements effecting coverage required by this clause. The endorsements are to be signed by a person authorized by that insurer to bind coverage on its behalf. The endorsements are to be in a form satisfactory to the Board. All endorsements are to be received and approved by the Board before work commences. As an alternative, the Contractor's insurer may provide complete, certified copies of all required insurance policies, including endorsements effecting the coverage required by these specifications.

Subcontractors

Contractor shall include all subcontractors as insureds under its policies or shall furnish separate certificates and endorsements for each subcontractor. All coverage for subcontractors shall be subject to all of the requirements stated herein.

Indemnity

The Contractor will save, keep and hold harmless CVWD, Board, its officers, officials, employees, agents, volunteers, and Consultants from all damages, costs or expenses in law or equity that may at any time arise or be claimed because of damages to property, or personal injury received by reason of or in the course of performing work, which may be caused by any willful or negligent act or omission by the Contractor or any of the Contractor's employees, or any subcontractor. Board will not be liable for any accident, loss or damage to the work before its completion and acceptance.

The cost of such insurance will be included in the various items of work in the Contractor's bid and no additional compensation for purchasing insurance or additional coverages needed to meet these requirements will be allowed.

In the event that any required insurance is reduced in coverage, cancelled for any reason, voided or suspended, Contractor agrees that Board may arrange for insurance coverage as specified, and Contractor further agrees that administrative and premium costs may be deducted from payments due to the Contractor.

END OF SECTION

SECTION B - GENERAL PROVISIONS MODIFICATIONS

B1.01 STANDARD SPECIFICATIONS

The work provided herein shall be performed in accordance with the Standard Specifications for Public Works Construction (SSPWC), 2018 Edition, adopted by the Greenbook Committee of Public Works Standards, Inc. Part 1, General Provisions, of the Standard Specifications is incorporated herein by reference except as modified below. Requirements of the Standard Specifications are intended to be construed in a complementary manner with all other provisions of the Contract Documents. However, in case of conflict between the Standard Specifications versus the General Provisions Modifications or other provisions of these Contract Documents (including Special Provisions), the General Provisions Modifications or other provisions (e.g. Special Provisions) of these Contract Documents shall control.

B1.02 MODIFICATIONS TO STANDARD SPECIFICATIONS

[General Provisions Modifications]

SECTION 1 – GENERAL

Paragraph 1-1

The following wording is added:

Wherever State Agencies, Departments, or Officers are referred to in the Standard Specifications, the comparable Board, Departments, or Officers are meant thereby for the purpose of these Contract Documents.

Paragraph 1-2

The following Terms and Definitions are added/modified:

General Manager:	The General Manager of the Carpinteria Valley Water District or his/her authorized representative.
Agent:	Shall include the Engineer and other persons and companies retained by the Board to perform design and construction services in relation to the Work other than the Contractor.
Board or Agency:	CARPINTERIA VALLEY WATER DISTRICT or its authorized representative
CVWD, District:	CARPINTERIA VALLEY WATER DISTRICT or its authorized representative
Consultants:	Water Systems Consulting, Inc.
Engineer:	Water Systems Consulting, Inc.
Days:	Working days.
Schedule of Values:	The submittal document referred to in Section 9, Paragraph 9-2 as modified herein of the Standard Specifications.

Standard Specifications

or SSPWC:

The "Standard Specifications for Public Works Construction," 2018 edition, as set forth in Section B1.01.

1-6 BIDDING AND SUBMISSION OF THE BID

Subsections 1-6.2 Subcontractor Listing of Subcontractors, of SSPWC has been deleted in its entirety and replaced with the following subsection.

1-6.2 Subcontractor Listing

Except as provided in Section 4100 et. seq. of the Public Contract Code, each bidder will file with its bid the name and location of the place of business of each subcontractor who will perform work or labor or render service to the prime Contractor in or about the construction of the work or improvement, or a subcontractor licensed by the State of California who, under subcontract to the prime contractor, specifically fabricates and installs a portion of the work or improvement according to detailed drawings contained in the plans and specifications, in an amount in excess of one-half of one percent of the prime contractor's total bid. Only one subcontractor will be listed for each portion of the work, which portion will be defined in the bid. In each instance, the nature and extent of the work to be sublet will be described. The failure of the Contractor to specify a subcontractor, or the listing of more than one subcontractor for the same portion of the work, constitutes an agreement by the Contractor that it is fully qualified to perform that portion itself and that it will perform that portion itself.

The Contractor shall have the written consent of the Board to substitute a subcontractor other than that designated in the original bid, to permit any subcontract to be assigned or transferred, or to allow a subcontract to be performed by other than the original subcontractor.

Subcontracting of work for which no subcontractor was designated in the original bid, and which is more than one-half of one percent of the work, will be allowed only in cases of public emergency or necessity, and then only after a finding reduced to writing as a public record of the Board setting forth the facts constituting the emergency or necessity.

Violation of any of the above provisions will be considered a breach of the contract, and CVWD may terminate the Contractor's control over the Work, cancel the contract, or assess the Contractor a penalty of not more than ten percent of the subcontract involved.

1.7 AWARD AND EXECUTION OF THE CONTRACT

The following subsections 1-7.3 and 1-7.4 are added to the SSPWC.

1.7-2 Contract Bonds

The following paragraph is added to Subsection 1-7.2 of the SSPWC.

The performance bond shall be paid up and in effect for one year after the acceptance of the job by CVWD in accordance with Subsection 3-13.3 Warranty.

1-7.3 Access to the Project Site

Not later than the date designated in the current Contract Schedule submitted by the Contractor, CVWD will provide access to the real property and facilities upon which the Work is to be performed,

including access to real property and facilities designated in the Contract Documents for the Contractor's use.

1-7.4 Ownership and use of the Contract Documents

The Contract Documents and all copies furnished to or provided by the Contractor are CVWD's property and may not be used on other work.

2.0 SCOPE OF THE WORK

2-2 PERMITS

The following is added to Subsection 2-2 of SSPWC:

Work performed in the public right-of-way in the City of Carpinteria is to be performed in accordance with the City of Carpinteria's Encroachment Permit. Contractor shall apply for all encroachment permits and provide all necessary information, including but not limited to traffic control plans for the applications. The Contractor shall obtain all other permits necessitated by their operations.

Copies of the Engineering Permit Applications are provided in Attachment A or can be accessed under the Public Works Department webpage in the City website <https://carpinteriaca.gov/public-works/engineering-division/engineering-permits-service/>. The Engineering Permit Application shows the Standard Conditions, which are the standard requirements. For Downtown Carpinteria as well as for any other neighborhood, attention is directed to Standard Condition No. 23 for public notification requirements. The City may also issue Special Conditions upon issuance of the permit, which can be found in Attachment A.

All permit and associated bonding fees, inspection permit fees or other fees charged or required for such permits shall be paid by the Contractor. These costs shall be included in the bid item for Mobilization.

2-3 RIGHT-OF-WAY

The following subsection is added to Subsection 2-3 of the SSPWC.

2-3.1 Additional Work Areas and Facilities

When the Contractor arranges for additional temporary work areas and facilities, the Contractor shall provide CVWD with proof that the additional work areas and/or facilities have been left in a condition satisfactory to the owner(s) of said work areas and/or facilities before acceptance of the work.

2-9 CHANGED CONDITIONS

Subsection 2-9, Changed Conditions, is deleted in its entirety and replaced with the following subsection:

If the Contractor encounters concealed or unknown conditions that differ materially from those anticipated or expected ("changed conditions"), the Contractor will immediately notify the Engineer

in writing of such changed conditions (upon discovery and before disturbing such changed conditions), as provided in Subsection 6-10, so that the Engineer can determine if such conditions require design details that differ from those design details shown in the Contract Documents. Notwithstanding the thirty (30) day time period set forth in Subsection 6-10.3, the Contractor will be liable to CVWD for any extra costs incurred as a result of the Contractor's failure to promptly give such notice.

Changed conditions will include, without limitation, the following:

1. Subsurface or latent physical conditions differing materially from those represented in the Contract Documents;
2. Unknown physical conditions of an unusual nature differing materially from those ordinarily encountered and generally recognized as inherent in work of the character being performed; and
3. Material differing from the represented in the Contract which the Contractor believes may be hazardous waste as defined in California Health & Safety Code § 25117 that is required to be removed to a Class I, II, or III disposal site in accordance with applicable law.

The Engineer will promptly investigate conditions that appear to be changed conditions. The Engineer's decision, and any dispute regarding that decision, will be made in accordance with Section 6-4 DELAYS AND EXTENSIONS OF TIME.

Any information provided pursuant to INFORMATION AVAILABLE TO BIDDERS is subject to the following provisions:

1. The information is made available for the Bidders' convenience and is not a part of the Contract.
2. CVWD has not determined the accuracy or completeness of such information and all such information is made available to Bidders without any representation or warranty by CVWD whatsoever as to its accuracy, completeness, or relevancy.
3. Bidders will independently evaluate such information for their use and will be solely responsible for use or interpretation of such information. Any such use or interpretation will not be the basis of any claim against CVWD.

2.10 DISPUTED WORK

Subsection 2.10 is deleted in its entirety and replaced by the following subsection.

If the Contractor and CVWD do not reach agreement on disputed work, CVWD may direct the Contractor to proceed with the work. Any payment for the disputed work will be determined pursuant to the claims procedures established herein. Although not to be construed as proceeding under extra work provisions, the Contractor shall keep and furnish records of disputed work as required by the Contract Documents.

3.0 CONTROL OF THE WORK

3.2 SELF PERFORMANCE

Add the following to Section 3.2 Self Performance:

The Contractor will submit experience statements for each subcontractor who will perform contract work that amounts to more than ten percent (10%) of the Work.

Reference is made to the Notice Inviting Bids. Designated specialty items, if any, are listed in the Notice Inviting Bids. The percentage requirement for performance of work with bidder's own forces shall be 50% less any designated specialty items in the Notice Inviting Bids. A lower or higher percentage may apply as indicated in the Notice Inviting Bids. The cost of materials/equipment, labor and incidentals shall be included in the calculation for determining the value of work for subcontracted items and will not be considered separately for the purpose of demonstrating an increased share of work performed by the General Contractor. The General Contractor cannot take credit for the purchase of material for work that is performed by a subcontractor for purposes of achieving the required percentage of work.

3-3 SUBCONTRACTORS

Section 3-3 Subcontractors, of SSPWC has been deleted in its entirety and replaced with the following subsection.

All persons engaged in the work, including subcontractors and their employees will be considered as employees of the Contractor. The Contractor will be solely responsible for and have control over construction means, methods, techniques, sequences, procedures, and the coordination of all portions of the Work. CVWD will deal directly with, and make all payments to the prime Contractor.

When subcontracted work is not being prosecuted in a satisfactory manner, the Contractor will be notified to take corrective action. The Engineer may report the facts to the General Manager. If the General Manager so orders, and on receipt by the Contractor of written instructions from the General Manager, the subcontractor will be removed immediately from the Work. That subcontractor will not again be employed on the Work.

Add: the following paragraphs to Section 7-6, The Contractor's Representative

SECTION 3-6 THE CONTRACTOR'S REPRESENTATIVE

Add: the following paragraph

A pre-construction conference and weekly meetings will be held at times and places to be designated by the Engineer. The Contractor's project manager and Representative and representatives of significant sub-contractors for this project shall attend. The Engineer will advise the Contractor as to which sub-contractors are deemed significant. Note that the project schedule is required to be submitted five (5) working days prior to the Pre-Construction Conference.

3.7 CONTRACT DOCUMENTS

Subsection 3-7.1 of the SSPWC is replaced by the following subsection.

3-7.1 General

The Contractor will maintain the following at the Work site:

1. One as-built copy of the Plans and Specifications, in good order and marked to record current changes and selections made during construction.
2. The current accepted Contract Schedule.
3. Shop Drawings, Product Data, and Samples.
4. All other required submittals.

The Plans, Specifications, and other Contract Documents will govern the Work. The Contract Documents are intended to be complementary and cooperative and to describe and provide for a complete project. Anything in the Specifications and not on the Plans, or on the Plans and not in the Specifications, will be as though shown or mentioned in both.

Payment for any items on the plans for which there is no specific bid item will be included in the various items of work or in any item to which it is appurtenant.

If the Contractor performs any work which it knows or should know involves an error, inconsistency, or omission without notifying and obtaining written consent from the Engineer, the Contractor will be responsible for the resulting losses, including, without limitation, the costs of correcting defective work.

3-7.2 Precedence of Contract Documents

The following paragraph is added to subsection 3-7.2 of the SSPWC:

As the figured dimensions shown on the plans and in the specifications of the Contract may not in every case agree with scaled dimensions, the figured dimensions will be followed in preference to the scaled dimensions, and plans to a large scale will be followed in preference to the plans to a small scale. Should it appear that the work to be done, or any of the matters relative thereto, are not sufficiently detailed or explained in the Contract, the Contractor will apply to the Engineer for such further explanations as may be necessary, and will conform thereto as part of the Contract so far as may be consistent with the terms thereof. Any items shown on drawings and not mentioned in the specifications will be of like effect as if shown or mentioned in both.

3-7.3 Accuracy of Plans and Specifications

The following subsection is added to Subsection 3-7 of the SSPWC.

Although it is believed that much of the information pertaining to conditions that may affect the cost of the Work will be shown on the Plans or indicated in the Specifications, CVWD does not warrant the completeness or accuracy of such information.

The Contractor will carefully study and compare each of the Contract Documents with the others and with information furnished by CVWD and will promptly report in writing to the Engineer any errors, inconsistencies, or omissions in the Contract Documents or inconsistencies with applicable

law observed by the Contractor.

The Contractor will take field measurements, verify field conditions, and carefully compare with the Contract Documents such field measurements, conditions, and other information known to the Contractor before commencing the Work. Errors, inconsistencies, or omissions discovered at any time will be promptly reported in writing to the Engineer.

Add: Paragraph 3-7.4 Suggestions to Contractor

Any plan or method of work suggested by the Board or the Engineer to the Contractor but not specified or required, if adopted or followed by the Contractor in whole or in part, shall be used at the risk and responsibility of the Contractor; and the Board and the Engineer shall assume no responsibility therefore and in no way be held liable for any defects in the work which may result from or be caused by use of such plan or method of work.

3-8.3 Shop Drawings

Subsection 3-8.3, Shop Drawings, of the SSPWC is deleted in its entirety and replaced by the following subsection:

The Contractor shall review, mark with approval and submit for review by the Engineer all shop drawings required by the Contract Documents. Six (6) sets of shop drawings shall be submitted to the Engineer and be accompanied by a letter of transmittal listing the drawings submitted. Drawings shall show the name of the projects, the name of the Contractor, and, if any, the names of suppliers, manufacturers, and subcontractors.

Shop Drawings shall be submitted with promptness and in orderly sequence so as to cause no delay in prosecution of the work.

Shop drawings shall be complete in all respects. If the shop drawings show any deviations from the requirements of the plans and specifications because of standard shop practices or other reasons, the deviations and the reasons therefor shall be set forth in the letter of transmittal.

By submitting shop drawings, the Contractor represents that material, equipment, and other work shown thereon conforms to the plans and specifications, except for any deviations set forth in the letter of transmittal.

Faxed documents will not be accepted. Digital documents may be accepted if that process is approved in advance by the Engineer.

The Engineer will, within three weeks of submittal receipt, return two of the copies of the drawings to the Contractor with any comments noted thereon. If so noted by the Engineer, the Contractor shall correct the drawings and resubmit them in the same manner as specified for the original resubmittal. The Contractor in the letter of transmittal accompanying resubmitted shop drawings shall direct specific attention to revisions other than the corrections requested by the Engineer on previous submittals.

The review by the Engineer is only of general conformance with the design concept of the project, and general compliance with the plans and specifications and shall not be construed as relieving the Contractor of the full responsibility for: providing materials, equipment, and work required by the

contract; the proper fitting and construction of the work; the accuracy, processes and techniques of construction; and performing the work in a safe manner.

No portion of the work requiring a shop drawing submittal shall commence until the submittal has been reviewed by the Engineer and returned to the Contractor with a notation indicating that resubmittal is not required. Any commitment made by the Contractor to purchase unapproved items shall be the Contractor's sole responsibility.

If the Contractor believes that any shop drawing or communication relative thereto calls for changes in the work for which the contract amount or time for completion should be changed, the Contractor shall not proceed with the changes in the work so called for and shall promptly notify the Engineer in writing of the estimated changes in the contract amount and time for completion believed to be appropriate. No payment for changes in the work will be made and no change in the time for completion by reason of changes in the work will be made, unless the changes are covered by a written change order approved by the Engineer in advance of the Contractor's proceeding with the changed work.

Submittals shall include, but are not limited to:

- a) Contract schedule (6-1)
- b) Key personnel, key personnel's telephone numbers & emergency telephone numbers (3-6)
- c) Business/Residence notification letter (5-9)
- d) Schedule of Values (7-2)
- e) Video data (900-2)

- f) Traffic Control Plan (900-5)
- g) Pothole Information Forms (Attachment C)
- h) Other submittals required by the plans and specifications.

Manufacturer's catalogs (or excerpts thereof) and affidavits of compliance with the contract documents shall be submitted for all materials to be used on the project.

Add: Paragraph 3-9.2 Non-Utility, Subsurface Obstacles

General excavation shall not damage existing active substructures. Hand labor excavation will be required within one (1) foot of existing substructures to remain in service.

3-10 NOT USED.

3-12 WORK SITE MAINTENANCE

3-12.4.2 Storage of Equipment and Materials in Public Streets

The first paragraph of subsection 3-12.4.2 is deleted in its entirety and replaced by the following:

Construction materials and equipment shall not be stored overnight within the City of Carpinteria's right-of-way unless approved by the City of Carpinteria's Representative.

3-12.6.1 NOT USED.

3-12. Cleanup and Dust Control

The following subsections are added to subsection 3-12, Work Site Maintenance, of the SSPWC.

3-12.7.1 General

The Contractor is required to comply with the latest edition at the time of bid opening of the Santa Barbara County Air Pollution Control District Fugitive Dust Control Regulations.

On any construction project requiring trenching within public streets, the Contractor shall sweep the street utilizing a pick-up type street sweeper a minimum of once daily unless otherwise allowed by the governing agency.

The Contractor shall prevent dust, grit, excessive noise, and other nuisances in and around the work areas during the entire contract period, including holidays and weekends.

The Contractor shall dispose of all excess excavated materials daily and bear all costs or retain any profit incidental to such disposal. No additional compensation will be allowed.

If the Contractor fails to maintain a clean site and control dust in accordance with these contract specifications, the Board reserves the right to hire another contractor or agency to perform this work and deduct the resulting cost plus CVWD overhead from the total contract price at final payment.

3-12.7.2 Watering/Temporary Water Meter

Water for the laying of dust caused by Contractor's operations shall be applied as necessary or as directed by the Engineer. Water shall not be used on streets to clean or to remove construction debris. A street sweeper shall be used to clean the streets (see Section 302-2.3.6 for sweeper specifications).

Water for the above or other construction purposes may be obtained through the use of a temporary service by applying for a temporary hydrant meter from Carpinteria Valley Water District (CVWD). Bidders are encouraged to verify costs prior to submitting a bid. All costs to be paid by the Contractor to CVWD shall be considered included in the Contractor's bid in the Mobilization item and no separate payment shall be made thereof.

3-13 COMPLETION, ACCEPTANCE, AND WARRANTY

The following subsection replaces Subsection 3-13 of the SSPWC.

The Contractor shall warrant and guarantee the entire Work and all parts thereof, including that performed and constructed by subcontractors and others employed directly or indirectly on the Work, against faulty or defective materials, equipment or workmanship for a period of one year from the date of acceptance of the Work. In addition thereto, for a period of one (1) year commencing on the date of acceptance of the Work, the Contractor shall, upon the receipt of notice in writing from

the Board, promptly make all replacements or repairs arising out of defective materials, workmanship or equipment and bear the cost thereof. Such Work shall be completed in a manner satisfactory to Board and within the time set forth in the Notice. The Board is hereby authorized to make such replacements or repairs and the Contractor and Surety shall bear the cost thereof if, ten (10) days after the giving of such notice to the Contractor, the Contractor has failed to make or undertake with due diligence the repairs or has failed to complete the Work in a manner satisfactory to the Board; provided, however, that, in the case of an emergency where, in the opinion of the Board, delay could cause serious loss or damage, replacements or repairs may be made without notice being sent to the Contractor or Surety, and all expense in connection therewith shall be charged to the Contractor and Surety.

For the purpose of this article "*acceptance of the Work*" shall mean the acceptance of the Work by the Board in accordance with Paragraph 6-8 but not for the purpose of extinguishing any covenant or agreement on the part of the Contractor to be performed or fulfilled under this Contract which has not in fact been performed or fulfilled at the time of such acceptance, all of which covenants and agreements shall continue to be binding on the Contractor until they have been fulfilled.

The effective date of acceptance of the Work and commencement of the Guaranty Period shall be the date of issue of the Notice of Completion.

4.0 CONTROL OF MATERIALS

Add: Paragraph 4-1.1 Retention of Defective Work

If, in the opinion of the Engineer, the defective work is not of sufficient magnitude or importance to make the work dangerous or undesirable, or if, in the opinion of the Engineer, the removal of such work is impractical or will create conditions which are dangerous or undesirable, the Board shall have the right and authority to retain such work instead of requiring it to be removed and reconstructed, but will make such deductions therefore in the payments due or to become due to the Contractor as the Board may deem just and reasonable.

Add: Paragraph 4-1.2 Manufacturer or Equipment Recommendations or Instructions

Where the manufacturer of any material or equipment provides written recommendations or instructions for its use or method of installation (including labels, tags, manuals, or trade literature), such recommendations or instructions shall be followed except for where the Contract Documents specifically require deviations.

4-3 INSPECTION

Subsection 4-3, Inspection Requirements, is deleted in its entirety and replaced by the following subsections.

4-3.1 General

The Work is subject to review and acceptance by the Engineer. The Contractor shall notify the Engineer before noon of the working day before review is required. Any work done without proper review will be subject to rejection. The Engineer and any authorized representatives shall at all times have access to the Work during its construction at shops and yards as well as the project site. The

Contractor shall provide every reasonable facility for ascertaining that the materials and workmanship are in accordance with these specifications. Review of the Work by the Engineer shall not relieve the Contractor of the obligation to fulfill all conditions of the Contract.

Unless otherwise specified, inspection at the source of production for such materials and fabricated items as bituminous paving mixtures, structural concrete, fabricated metal products, cast metal products, welding, reinforced and unreinforced concrete pipe, application of protective coatings, and similar shop and plant operations is not required. A certificate of compliance, signed by an authorized officer of the producer, certifying compliance with the contract documents will be submitted for all of the following materials: cement and any supplementary cementitious materials, aggregate; subject to sampling and testing by CVWD.

Standard items of equipment, such as electric motors, conveyors, plumbing fittings and fixtures, lumber, plywood, and so on, are subject to inspection at the job site.

All other equipment items will be inspected and tested in accordance with the contract documents.

Any inspection required outside of normal working hours and days, including holidays, will be at the Contractor's cost at rates established by CVWD.

4-3.3 Inspection of Materials not Locally Produced

Contractor purchased materials, fabricated items, and equipment, produced at sources located more than 50 miles outside Santa Barbara County, and which are specified to be inspected in the contract documents, will be inspected by inspectors or testing laboratories arranged for and paid for by CVWD unless otherwise specified. If any item inspected fails to meet the specified criteria, Contractor will pay all costs for reinspection, and such costs may be deducted from payments due to Contractor.

4-6 Trade Names

The first paragraph of Subsection 4-6 of the SSPWC is deleted and is replaced with the following paragraphs:

The Contractor may supply any material, product, thing and/or service specified or offer an equivalent, unless the trade name or model number of the item is followed by the words "no substitution", "no substitute", "no equal", or similar language.

Pursuant to Public Contract Code Section 3400(b), CVWD has made the following finding as it relates to the need for the use of specific materials, products, things and/or services that must be utilized for the Project: In order to match other products in use, either completed or in the course of completion at other CVWD Facilities, all specific materials, products, things and/or services that are listed by brand name and/or model number in the specifications and proceeded with the words "no substitution", "no substitute", "no equal", or similar language are required and may not be substituted with an "equal" item of different brand name and/or model number.

5.0 LEGAL RELATIONS AND RESPONSIBILITIES

Add: Paragraph 5-2.1 Legal Address and Service of Notice

- A. Legal Address of the Board - The address of the Board shall be 1301 Santa Ynez Ave. Carpinteria, CA 93013 or such address as may be subsequently designated by the Board in written notice to the Contractor.
- B. Legal Address of the Contractor - The address of the Contractor shall be such address as may be subsequently designated by the Contractor in written notice to the Board.

5-3 LABOR

5-3.2 Prevailing Wages

Subsection 5-3.2, Prevailing Wages, of the SSPWC is deleted in its entirety and replaced with the following.

The Contractor will post at appropriate conspicuous points at the site of the project a schedule showing determinations of the Director of Industrial Relations of the prevailing rate of per diem wages. It will be the Contractor's responsibility to obtain copies of the prevailing rate of per diem wages. One source that may be used is the California Department of Industrial Relations website which is currently located at www.dir.ca.gov, or by calling the Prevailing Wage Unit at (415) 703-4774.

In accordance with Section 1775 of the Labor Code, the Contractor will forfeit as a penalty to CVWD, \$25.00 for each calendar day or portion thereof, for each workman paid less than the stipulated prevailing rates for such work or craft in which such workman is employed for any work done under the contract by him or by any subcontractor under him. In addition to said penalty and pursuant to the said Section 1775, the difference between the stipulated prevailing wage rates and the amount paid to each workman for each calendar day or portion thereof, for which each workman was paid less than the stipulated prevailing wage rate will be paid to each workman by the Contractor. Any sums forfeited under the provisions of this section will be deducted from the payments under this contract by CVWD.

Attention is directed to the provisions in Sections 1777.5, 1777.6 and 3098 of the Labor Code concerning the employment of apprentices by the Contractor or any subcontractor under him.

Section 1777.5 requires the Contractor or subcontractor employing tradesmen in any apprenticeship occupation to apply to the joint apprenticeship committee nearest the site of the public works project and which administers the apprenticeship program in that trade for a certificate of approval. The certificate will also fix the ratio of apprentices to journeymen that will be used in the performance of the contract. The ratio of apprentices to journeymen in such cases will not be less than one to five except:

- a) When employment in the area of coverage by the joint apprenticeship committee has exceeded an average of 15 percent in the 90 days before the request for certificate, or
- b) When the number of apprentices in training in the area exceeds a ratio of one to five, or
- c) When the trade can show that it is replacing at least 1/30 of its membership through apprenticeship training on an annual basis state-wide or locally, or

- d) When the Contractor provides evidence that he employs registered apprentices on all of his contracts on an annual average of not less than one apprentice to eight journeymen.

The Contractor is required to make contributions to funds established for the administration of apprenticeship programs if he employs registered apprentices or journeymen in any apprenticeable trade on such contracts and if other contractors on the public works site are making such contributions.

The Contractor and any subcontractor under him will comply with the requirements of Sections 1777.5 and 1777.6 in the employment of apprentices.

Information relative to apprenticeship standards, wage schedules and other requirements may be obtained from the Director of Industrial Relations, ex-officio the Administrator of Apprenticeship, San Francisco, California, or from the Division of Apprenticeship Standards and its branch offices.

5-3.6 Record of Wages Paid: Inspection

The following subsection is added to section 5-3 of the SSPWC.

Every Contractor and subcontractor will keep an accurate record showing the name, occupation, and the actual per diem wages paid to each workman employed by him in connection with the public work. The record will be kept open at all reasonable hours to the inspection of the body awarding the contract and to the Division of Labor Law Enforcement. Upon request by the Engineer, the Contractor shall submit to the Engineer within 14 calendar days of the request, copies of Record of Way paid (certified payroll) to each workman, including subcontractors employed by him in connection with the public works project.

Payments will be withheld from Contractor for failure to keep an accurate record of wages paid and to make such records available to CVWD. Contractor shall not be entitled to any additional compensation from delays in payment by CVWD due to Contractor's failure to satisfy the above requirements.

5-4 INSURANCE REQUIREMENTS FOR CONTRACTORS

This section is deleted, and reference is made to Section A-4.

5-7 SAFETY

5-7.1.1 Protection of the Work and Public Safety

The following is added to subsection 5-7.1.1 of the SSPWC.

As modified herein by the special provisions. The Contractor is responsible for protecting its work and public safety at the work site from the time the contractor first mobilizes onto the site and until final acceptance.

The Contractor shall provide whatever means necessary to protect the public at the work site. The Contractor is responsible for determining and then implementing all means necessary to protect and

secure the site. The Contractor shall expect unauthorized persons to enter onto the work site both during work hours and outside of construction work hours. CVWD will not be responsible for any damage to the work, damage or theft of Contractor's equipment and materials, or for Contractor's failure to provide adequate measures to protect the public from harm.

At a minimum, the Contractor shall install and maintain temporary fencing, at least 6-feet in height with lockable gates along the perimeter of its staging/storage and stockpile area in order to secure materials and equipment and to protect the public from harm. See subsection 5-7.7.2 of the SSPWC.

At a minimum, Contract shall install and maintain temporary fencing, plating (plywood or steel), temporary backfill or similar measures in order to protect the public from any excavations that are not backfilled prior to the end of each workday that may pose a danger to the public. See subsection 5-7.8 of the SSPWC.

Payment for Protection of the Work and Public Safety shall be considered included in other listed items of the bid, and no separate payment will be made thereof.

The following Subsection is added to Section 5.0 of the SSPWC:

5-8 HAZARDOUS MATERIAL

For any excavation which extends more than four feet below existing grade, the Contractor shall promptly, and before the conditions are disturbed, notify the Engineer, in writing, of 1) any material that the Contractor believes may be hazardous waste, as defined in Section 25117 of the Health and Safety Code, which is required to be removed to a Class I, Class II, or Class III disposal site in accordance with provisions of existing law, 2) subsurface or latent physical conditions at the site differing from those indicated, or 3) unknown physical conditions at the site of any unusual nature, different materially from those ordinarily encountered and generally recognized as inherent in work of the character provided for in the Contract Documents.

Upon notification by the Contractor that any of the conditions described above exist, CVWD will promptly investigate. The rights and obligations of CVWD and the Contractor with regard to said conditions (including, but not limited to, the procedures for procuring change orders and filing claims) will be specified by the provisions of Subsection 2-9 (Changed Conditions) of the SSPWC.

If a dispute arises between CVWD and the Contractor whether the conditions materially differ, involve hazardous waste, or cause a change in the Contractor's cost or time required for performance of the work, the Contractor will not be excused from any scheduled completion date provided for by the contract, but will proceed with all work to be performed under the contract. The Contractor will retain all rights provided by Subsection 2-10, Disputed Work, of the SSPWC.

If CVWD determines that material called to the Engineer's attention by the Contractor is hazardous waste, or if CVWD otherwise discovers the existence of hazardous waste, the Contractor shall be responsible for removal and disposal of the hazardous waste by qualified personnel and appropriate equipment in the manner required by law as directed by CVWD, subject to the provisions of Section 2 (Scope of Work) and Section 7 (Measurement and Payment) of the SSPWC.

If excavated material with hydrocarbon odor or discoloration is encountered, the Contractor shall stop work immediately and notify CVWD and the County Department of Environmental Health Services at (805) 681-4900. Once a hazardous materials staff person has determined the material to be hazardous, CVWD may choose to dispose of hydrocarbon contaminated soil in a Class 2

landfill. All materials must be disposed in accordance with State, County, and local regulations. CVWD will provide laboratory testing services to analyze the material.

The following Subsection is added to Section 5.0 of the SSPWC:

5-9 STANDARD NOTIFICATIONS

The Contractor shall deliver notices to each business and resident adjacent to the work site included within this contract at least five (5) calendar days prior to beginning work as specified. The Contractor shall obtain advance approval by CVWD for the distribution area, notice format and content (refer to the following example).

Such notice shall, at minimum, give the start date of the work, the daily schedule for the proposed work, the typical parking restriction for the work, the times of any restricted driveway access, the Contractor's representative and phone number, the CVWD's representative and phone number, and any other information requested by CVWD.

All notices shall be in the format of door hangers (14 inches by 4 inches, 110 Springhill Index or approved equal) and be hung at the main door of each residence or business affected. The text of such notices shall have one side printed in English and the reverse side printed in Spanish.

Full compensation for standard notifications shall be considered incidental to the project and no separate payment shall be made. All costs related to standard notifications shall be included in the item for Mobilization.

The following is an example of the required language for standard notifications.

NOTICE

TO AREA BUSINESSES & RESIDENTS

 (Contractor) , will be performing Construction as part of the POTHOLING SERVICES FOR THE CARPINTERIA ADVANCED PURIFICATION PROJECT

Work in your area will begin on (Date) between the hours of 7:00 a.m. and 4:00 p.m. local access will be maintained during most of the work, however, some access restrictions will be in effect during the work hours. Any access restrictions will be posted 72 hours in advance of the work.

We appreciate your patience and understanding during the inconvenience. If you have any questions or require additional information, please contact the following:

(Contractor's Name), (Contact's Name), (Contact's Telephone Number)
(Board's Representative), (Contact's Name), (Telephone Number)

The District will provide notices to their customers regarding service interruptions. The Contractor shall provide a minimum of 5 working days' notice to the District prior to any service interruptions.

6-1 CONSTRUCTION SCHEDULE AND COMMENCEMENT OF WORK

Section 6-1, Construction Schedule and Commencement of Work, is deleted in its entirety and replaced by the following subsections.

6-1.1 Contract Schedule

The Contractor shall submit a Contract Schedule to the Engineer 5 working days prior to the Pre-Construction Conference. The Engineer will review the Contract Schedule with the Contractor within fifteen (15) days after submittal.

6-1.2 Content of Contract Schedule

The Contract Schedule, and any updated Contract Schedule, will meet the following requirements:

1. Schedules shall be suitable for monitoring progress of the Work.
2. Schedules shall provide necessary data about the time for the Engineer's decisions.
3. Schedules shall be sufficiently detailed to demonstrate adequate planning for the Work.
4. Schedules shall represent a practical plan to complete the Work within the Contract Time.
5. Schedules shall show the critical path method for completing the Work.
6. Schedule shall be submitted to the Engineer in printed paper format and computer digital electrical format on compact disc (CD).

The Engineer's review of the form and general content of the Contract Schedule and any updated Contract Schedules is for the purpose of determining if the listed requirements are satisfied.

The Contractor shall update the Construction Schedule when directed by the Engineer, or when:

- A. A change order significantly affects the Contract completion date or the sequence of construction approach or activities.
- B. The actual sequence of the Work, or the planned sequence of the Work is changed and does not conform to the Contractor's current accepted project Construction Schedule.
- C. The Contractor falls more than ten (10) percentage points behind the schedule based on a comparison of the scheduled value of work to be completed and the sum of the earned progress payments.

The Contractor shall revise and update the Construction Schedule within the progress payment period in which the change in the schedule takes place and shall submit to the Engineer four (4) printed copies of the revised Construction Schedule with his monthly progress payment request for

that period. Preparation and updating of Construction Schedule shall be performed at Contractor's sole expense.

Failure by the Contractor to submit updated or revised Construction Schedules when required may prevent acceptance of progress payment requests by CVWD until such updated or revised Construction Schedules have been submitted for review and the Engineer's review has been completed.

6-1.3 Effect of Contract Schedule

The Contract Schedule, and any updated Contract Schedules, will represent a practical plan to complete the Work within the Contract Time. Extension of any schedule beyond the Contract Time will not be acceptable. Schedules showing the Work completed in less than the Contract may be acceptable if judged by the Engineer to be practical.

Acceptance of such a schedule by the Engineer will not change the Contract Time. The Contract Time, not the Contract Schedule, will control in determining liquidated damages payable by the Contractor and in determining any delay.

If a schedule showing the Work completed in less than the Contract Time is accepted, the Contractor will not be entitled to extensions of the Contract Time for Excusable Delays or Compensable Delays or to adjustments of the Contract Sum for Compensable Delays until such delays extend the completion of the Work beyond the expiration of the Contract Time.

The Contractor will plan, develop, supervise, control, and coordinate the performance of the Work so that its progress and the sequence and timing of Work activities conform to the current accepted Contract Schedule.

The Contractor will continuously obtain from Subcontractors information and data about the planning for and progress of the Work and the delivery of equipment, will coordinate and integrate such information and data into updated Contract Schedules, and will monitor the progress of the Work and the delivery of equipment. The Contractor will act as the expeditor of potential and actual delays, interruptions, hindrances, or disruptions for its own forces and those forces of Subcontractors. The Contractor will cooperate with the Engineer in developing the Contract Schedule and updated Contract Schedules.

The Engineer's review and comments about any schedule or scheduling data will not relieve the Contractor from its sole responsibility to plan for, perform, and complete the Work within the Contract Time. Review and comments about any schedule will not transfer responsibility for any schedule to the Engineer or CVWD nor imply their agreement with (1) any assumption upon which such schedule is based or (2) any matter underlying or contained in such schedule.

The Engineer's failure to discover errors or omissions in schedules that have been reviewed, or to inform the Contractor that the Contractor, Subcontractors, or others are behind schedule, or to direct or enforce procedures for complying with the Contract Schedule will not relieve the Contractor from its sole responsibility to perform and complete the Work within the Contract Time and will not be a cause for an adjustment of the Contract Time or the Contract Sum.

The Contractor will perform the Work in accordance with the currently accepted Contract Schedule.

6-1.4 Schedule Delay

If, in the Engineer's opinion, the Contractor has fallen behind the accepted Construction Schedule by more than fifteen (15) percentage points based on earned progress payments, the Contractor shall take steps, including, but not limited to, increasing the number of personnel, shifts, and/or overtime operations, days of work, and/or amount of construction equipment until such time as the Work is back on schedule. He shall also submit for review no later than the next request for partial payment, such supplementary schedule or schedules as may be deemed necessary to demonstrate the manner in which the rate of progress will be regained. All costs required to bring the Project back on schedule shall be born by the Contractor without additional cost to the Board.

If, in the Engineer's opinion, the Contractor falls behind the accepted construction schedule, as modified by such time extensions as may have been granted by the Board for unavoidable delays, by more than thirty-five (35) percentage points based on earned progress payments, he shall be deemed in material breach of Contract and the Work turned over to the Surety for completion within the scheduled time.

6-1.5 Commencement of Contract Time

The Contract Time will commence when CVWD issues a Notice to Proceed. The Work shall start within fifteen (15) working days thereafter and be diligently prosecuted to completion with the time provided in the Specifications. Notwithstanding any other provision of the contract, the Board is not obligated to accept or to pay for any work furnished by the Contractor prior to delivery Of Notice to Proceed whether or not the Board has knowledge of the furnishing of such work.

6-1.6 Final Job Walk-through Meeting

The Contractor shall attend the Final Job Walk-through Meeting to be held prior to final payment at a time designated by the Engineer.

The Contractor shall provide the following at the final job walk-through meeting:

- 1) Contract Documents
- 2) All tools and labor to inspect the Contractors work
- 3) Any as-builts not yet submitted.

6-2 PROSECUTION OF THE WORK

The following subsection is added to Section 6-2 of the SSPWC.

Revise: Paragraph 6-2 Prosecution of Work

Replace the last sentence of the first paragraph, to read as follows: "Should Contractor fail to take the necessary steps to fully accomplish these purposes, after order of CVWD to do so, the Board may suspend the work in whole or in part, until the Contractor takes such steps at no cost to the Board."

6-2.1 Work Hours

Except for work of an emergency nature, as determined by CVWD, the Contractor's construction activities are subject to limited work hours at the following locations and times:

A. General:

7:00 A.M. to 5:00 P.M., Monday through Friday (except holidays). Work performed outside of these hours, Saturdays, Sundays and legal holidays shall be by approval of the CVWD Engineer only. The Contractor shall be responsible for all inspection costs for work done outside of these work hours.

B. Work Activities within City of Carpinteria's right-of-way:

For work within the City of Carpinteria's right-of-way, reference is made to the Conditions of the City of Carpinteria's Encroachment Permit.

Add Subsection 6-2.2 Protection and Restoration of Existing Improvements

Interference and damage to existing improvements, utilities, buildings, irrigation, landscaping, and appurtenances by the Contractor, must be repaired by and rectified at the Contractor's expense and to the CVWD's approval and satisfaction. The Contractor shall repair the damage within 15 working days after the damage occurred.

Reconstruction shall be of like material, with the same finish, and in not less than the same dimensions as the original work. Repairs to concrete work shall be made by removing and replacing the entire section between joints or scores (and not merely refinishing any damaged part). All work shall match the color, texture, quality and joint location of the existing improvements.

Full compensation for protection and restoration of existing improvements shall be considered as incidental to the project and no separate payment shall be made. All costs relate to protection and restoration of existing improvements shall be included in the various other applicable items of work.

Add Subsection 6-2.3 Existing Trees and Vegetation

Any large roots (over three inches in diameter) must be cleanly cut using a chain saw or other sawing tool. Wherever possible, root pruning shall be performed on one side of the tree at a time.

All cultivated and landscaped areas and other surface improvements, which are damaged or disturbed by actions of the Contractor, shall be restored as nearly as possible to their original condition meeting CVWD's approval at Contractor's expense.

Full compensation for work on existing trees and vegetation shall be considered as incidental to the project and no separate payment shall be made. All costs related to work on existing trees and vegetation shall be included in the various other applicable items of work.

Add Subsection 6-2.4 Access

Access to street intersection, public and private parking lots, commercial businesses, residences and other public and private properties shall be maintained at all times. No streets may be shut down for construction. At least 72 hours in advance of starting any work that may affect the access to private properties, the Contractor shall provide written notice to such property Owners. Vehicular

access to and from commercial and residential driveways and parking lots shall be maintained at all times, except when performing items of work that cannot be accomplished without access restriction. When access must be restricted, as determined by CVWD, it shall occur only for the time period absolutely required to accomplish the particular item of work. Pedestrian access shall be maintained at all times. If work interferes with bus routes, the contractor shall be responsible for notifying MTD (local bus service) one week in advance for rerouting of bus service.

6-3 TIME OF COMPLETION

Add: Paragraph 6-3.3 Night Work

The following paragraph is added to Section 6-3 of the SSPWC:

Work between the hours of 5 p.m. and 7 a.m. of the following day will not be permitted unless specifically provided for in the contract documents or unless the Contractor receives prior written approval from CVWD.

Add: Paragraph 6-3.4 Punch List Completion

The Contractor shall complete all punch list items within 14 days of the final job walk. If the Contractor fails to complete the punch list work within this period, the Board may hire another Contractor to complete the work and deduct the costs of such work from future payments.

Add: Paragraph 6-3.5 Working Days

A working day is any day within the period between the date of the start of the Contract time and the date of the field acceptance of the Work by the Engineer, other than:

1. Saturday,
2. Sunday,
3. any day designated as a holiday by CVWD,
4. any other day designated as a holiday in a Master Labor Agreement entered into by the Contractor or on behalf of the Contractor as an eligible member of a contractor association,
5. any day the Contractor is prevented from working at the beginning of the workday for cause as specified in 6-4.1, or
6. any day the Contractor is prevented from working during the first 5 hours with at least 60 percent of the normal work force for cause as specified in 6-4.1.

6-4 DELAYS AND EXTENSIONS OF TIME

Subsections 6-4.1 to 6-4.4 are deleted and replaced with the following subsections.

6-4.1 Notice of Delays

Whenever the Contractor foresees any delay in the prosecution of the work, and in any event immediately upon the occurrence of any delay which the Contractor regards as unavoidable, he shall notify CVWD in writing of the probability of the occurrence of such delay and its cause in order that CVWD may take immediate steps to prevent, if possible, the occurrence or continuance of the delay, or, if this cannot be done, may determine whether the delay is to be considered avoidable or unavoidable, how long it continues, and to what extent the prosecution and completion of the work

are to be delayed thereby. It will be concluded that any and all delays which have occurred in the prosecution and completion of the work have been avoidable delays, except such delays as shall have been called to the attention of CVWD at the time of their occurrence and found by CVWD to have been unavoidable.

The Contractor shall make no claims for any delay not called to the attention of CVWD at the time of its occurrence as an unavoidable delay.

If delays are caused by unforeseen events beyond the control of the Contractor, such delays will entitle the Contractor to an extension of time as provided herein, but the Contractor will not be entitled to damages or additional payment due to such delays except as otherwise provided herein. Excusable delay may include: war, government regulation, labor disputes outside the contemplation of the parties, strikes outside the contemplation of the parties, fires, floods, changes to the Work as identified herein, or other specific events that may be further described in the Specifications.

Delays to the project caused by labor disputes or strikes involving trades not directly related to the project, or involving trades not affecting the project as a whole will not warrant an extension of time.

CVWD will not grant an extension of time for a delay by the Contractor's inability to obtain materials unless the Contractor furnishes to documentary proof acceptable to the Engineer. The proof shall be provided in a timely manner in accordance with the sequence of the Contractor's operations and accepted construction schedule.

Should delays be caused by events other than those included herein, CVWD may, but is not required to, deem an extension of time to be in CVWD's best interests.

6-4.2 Extensions of Time

If granted, extensions of time will be based upon the effect of delays to the critical path of the Work as determined by the current accepted Contract Schedule. Delays to minor portions of the Work that do not affect the critical path will not be eligible for extensions of time.

6-4.3 Payment for Delays to Contractor

Any payment for compensable delay will be based upon actual costs as set forth in Section 7-4 PAYMENT FOR EXTRA WORK excluding, without limitation, what damages, if any, the Contractor may have reasonably avoided. The Contractor understands that this is the sole basis for recovering delay damages and explicitly waives any right to calculate daily damages for office overhead, profit, or other purported loss, using different formulas including, without limitation, the Eichleay Formula.

Equipment idle time will be calculated in accordance with Subsection 7-4.2.3 as modified herein and based upon the actual normal working time during which the delay condition exists, but shall in no case exceed 8 hours in any one day. The days for which compensation will be paid will be the calendar days, excluding Saturdays, Sundays and legal holidays, during the existence of the delay.

Worker idle time will be calculated in accordance with Subsection 7-4.2.1.

6-4.4 Written Notice and Report

If the Contractor desires payment for a delay or an extension of time, it will give the Engineer written notice of such request not later than the time limit set forth in Proposal for submitting a claim after the event or occurrence giving rise to a delay claim. Failure to submit a written request within such amount of time will result in the Contractor waiving its delay claim.

Any such claim for payment or an extension of time shall be in the form required by the "Claims" sections of these Specifications.

In no event will CVWD grant the Contractor an extension of time if the delay is within the Contract Time as identified by the Contract Documents.

6-9 LIQUIDATED DAMAGES

Subsection 6-9, Liquidated Damages, of the SSPWC is deleted in its entirety and replaced by the following subsections.

6-9.1 Failure to Complete Work on Time

If all the work called for under the contract is not completed before or upon the expiration of the Contract Time, damage will be sustained by CVWD. Since it is and will be impracticable to determine the actual damage which CVWD will sustain in the event of and by reason of such delay, it is therefore agreed that the Contractor will pay to CVWD the sum specified in the Proposal for each and every calendar day beyond the time prescribed to complete the work not as a penalty, but as a predetermined liquidated damage. The Contractor agrees to pay such liquidated damages as are herein provided, and in case the same are not paid, agrees that CVWD may deduct the amount thereof from any money due or that may become due to the Contractor under the contract.

6-9.2 Disruption of South Coast Conduit (SCC) Operations

Contractor activities shall not interrupt, impede, or interfere with the SCC operations. Disruption of SCC operations will result in loss of water service that may pose a risk to public health, and that may result in regulatory fines or other sanctions. In the event of such an unauthorized disruption of SCC operations, the Contractor will pay to CVWD the sum specified in the Proposal for each hour in which the operation of the SCC is disrupted. This sum is not a penalty, but predetermined liquidated damages. The Contractor agrees to pay such liquidated damages as are provided for in this paragraph, and in case the same are not paid, Contractor agrees that CVWD may deduct such liquidated damages from any money that is due or may become due to the Contractor under the Contract.

6-9.3 Service Interruptions

Contractor shall not interrupt service to District Customers outside the hours stipulated on the plans. In the event of such an unauthorized disruption of SCC operations, the Contractor will pay to CVWD the sum specified in the Proposal for each hour in which the operation of the SCC is disrupted. This sum is not a penalty, but predetermined liquidated damages. The Contractor agrees to pay such liquidated damages as are provided for in this paragraph, and in case the same are not paid, Contractor agrees that CVWD may deduct such liquidated damages from any money that is due or may become due to the Contractor under the Contract.

Additionally, should it be necessary for CVWD to perform work by CVWD Forces or by other contract services to mitigate an unauthorized disruption to water distribution services, the full and complete time and material cost for these services will be paid by the Contractor.

Section 6-10, Disputes and Claims; Procedure, is added to the SSPWC to read as follows:

6-10 DISPUTES AND CLAIMS; PROCEDURE

6-10.1 General

“Claim” means a written demand or assertion by the Contractor that seeks an adjustment or interpretation of the terms of the Contract Documents, payment of money, extension of time, or other relief with respect to the Contract Documents, including a determination of disputes or matters in question between CVWD and the Contractor arising out of or related to the Contract Documents or the performance of the Work, and claims alleging an unforeseen condition or an act, error, or omission by CVWD, the Engineer, their agents or employees. “Claim” does not mean, and the Claims procedures herein do not apply, to the following:

1. Claims respecting penalties for forfeitures prescribed by statute or regulations which a government agency is specifically authorized to administer, settle, or determine. Claims respecting personal injury, death, reimbursement, or other compensation arising out of or resulting from liability for personal injury or death.
2. Claims respecting a latent defect, breach of warranty, or guarantee to repair.
3. Claims respecting stop notices.

If a Claim is subject to the Change Order procedures, the Claim arises upon the issuance of a written final decision denying in whole or in part the Contractor’s Change Order Request. If a Claim is not subject to the Change Order Procedures, the Claim arises when the Contractor discovers, or reasonably should discover, the condition or event giving rise to the Claim.

6-10.2 Form

A Claim shall include the following:

1. A statement that it is a Claim and a request for a decision.
2. A detailed description of the act, error, omission, unforeseen condition, event or other condition giving rise to the Claim.
3. If the Claim is subject to the Change Order procedures, a statement demonstrating that a Change Order Request was timely submitted and denied.
4. A detailed justification for any remedy or relief sought by the Claim, including to the extent applicable, the following:
 - a) If the Claim involves extra work, a detailed cost breakdown claimed. The breakdown shall be provided even if the costs claimed have not been incurred when the Claim is

submitted.

- b) To the extent costs have been incurred when the Claim is submitted, the Claim shall include actual cost records (including, without limitation, payroll records, material and rental invoices) demonstrating that costs claimed have actually been incurred.
- c) To the extent costs have not yet been incurred at the time the Claim is submitted, actual cost records shall be submitted on a current basis not less than once a week during any periods costs are incurred. A cost record will be considered current if submitted within 7 days of the date the cost reflected in the record is incurred. At the Engineer's request, claimed extra costs may be subject to further verifications procedures (such as having an inspector verify the performance of alleged extra work on a daily basis).

5. If the Claim involves an error or omission in the Contract Documents:

- a) An affirmative representation that the error or omission was not discovered before submitting a bid for the Contract; and
- b) A detailed statement demonstrating that the error or omission reasonably should not have been discovered by the Contractor, its Subcontractors and suppliers, before submitting a bid for the Contract.

6. If the Claim involves an extension of the Contract Time, written documentation demonstrating the Contractor's entitlement to a time extension.

7. If the Claim involves an adjustment of the Contract Sum for delay, written documentation demonstrating the Contractor's entitlement to such an adjustment.

8. A personal certification from the Contractor that reads as follows:

"I, _____, BEING THE _____ (MUST BE AN OFFICER) OF _____ (GENERAL CONTRACTOR), DECLARE UNDER PENALTY OF PERJURY UNDER CALIFORNIA LAW, AND DO PERSONALLY CERTIFY AND ATTEST THAT I HAVE THOROUGHLY REVIEWED THE ATTACHED CLAIM FOR ADDITIONAL COMPENSATION AND/OR EXTENSION OF TIME, AND KNOW ITS CONTENTS, AND SAID CLAIM IS MADE IN GOOD FAITH; THE SUPPORTING DATA IS TRUTHFUL AND ACCURATE; THAT THE AMOUNT REQUESTED ACCURATELY REFLECTS THE CONTRACT ADJUSTMENT FOR WHICH THE CONTRACTOR BELIEVES CVWD IS LIABLE; AND, FURTHER, THAT I AM FAMILIAR WITH CALIFORNIA PENAL CODE § 72 AND CALIFORNIA GOVERNMENT CODE § 12650, ET SEQ., PERTAINING TO FALSE CLAIMS, AND FURTHER KNOW AND UNDERSTAND THAT SUBMITTING OR CERTIFYING A FALSE CLAIM MAY LEAD TO FINES, IMPRISONMENT, AND/OR OTHER SEVERE LEGAL CONSEQUENCES."

6-10.3 Claims Submitted to General Manager

Within 30 days after the Claim arises, the Contractor will submit its Claim to the CVWD General Manager for a decision. Regardless of any Claim submittal, or any dispute regarding a Claim, unless otherwise directed by the General Manager, the Contractor will not cause any delay, cessation, or

termination of the Work, but will diligently proceed with the performing the Work in accordance with the Contract Documents. Except as otherwise provided, CVWD will continue to make payments in accordance with the Contract Documents.

6-10.4 Claim is Prerequisite to other Remedy

The Contractor understands and agrees that submitting a claim in accordance with these Specifications is an express condition precedent to the Contractor's right to otherwise pursue a claim whether through alternative dispute resolution or by litigation. Should the Contractor fail to submit a claim in accordance with these Specifications, including the time limits set forth herein, it will waive any right to a remedy, whether in law or equity, it might otherwise have pursuant to the Contract Documents or applicable law.

6-10.5 Decision on Claims

The General Manager will promptly review Claims submitted by the Contractor in accordance with these Specifications. Should the General Manager require additional supporting evidence to evaluate the claim, the General Manager will request such additional information in writing. Any such requested data will be furnished not later than 10 days after the Contractor receives the General Manager's request.

The General Manager will render a decision not later than 30 days after either receiving the Claim or the deadline for furnishing additional supporting data, whichever is later. If the Claim amount is more than \$50,000, the time period will be extended to 60 days. If the General Manager fails to render a decision within the time period established herein, then the Claim will be deemed denied. The General Manager's decision will be final and binding unless appealed in accordance with these Specifications.

6-10.6 Appeal of General Manager's Decision to the Board

Should the Contractor dispute the General Manager's decision, the Contractor shall have 30 days to submit an appeal of that decision to the Board. The appeal shall include all necessary supporting data. The Board will conduct a hearing on a date mutually convenient to CVWD and the Contractor at which relevant evidence will be taken regarding the claim or dispute. The Board or its designee shall have discretion to determine the facts and will issue a written decision within 30 days of the completion of the hearing.

The Board's decision on a Claim will include a statement substantially as follows:

"This is a decision pursuant to the General Specifications or your contract. If you are dissatisfied with the decision, and have complied with the procedural requirements for asserting claims, you may have the right to mediation, arbitration or litigation. Should you fail to take appropriate legal action within certain dates of this decision as outlined in section 6-10 of the General Specifications, this decision will become final, binding and not subject to mediation, arbitration, litigation or appeal."

6-10.7 Mediation

If the Contractor disputes the Board's decision, then the Contractor shall demand mediation as per section 6-10.7 within 30 days of the Board's decision.

If the parties cannot agree on the appointment of a mediator within thirty days of mediation being demanded, then the appointment of the mediator will be conducted by the American Arbitration Association under its Construction Industry Mediation Rules. California Evidence Code §1115 et seq. regarding the confidentiality of mediations will be applicable to the mediation process.

The mediation process will not alter or modify the time limitations with respect to the claim process outlined in sections 6-10.1 through 6-10.6 above, and CVWD's conduct or settlement negotiations during the mediation process will not be considered a waiver by CVWD of its right to assert a failure to comply with the claim procedures as a defense.

The mediator's fee will be borne equally by the parties to the mediation. The parties may be, but are not required to be, represented by an attorney during the mediation process.

6-10.8 Arbitration

If the mediation process outlined in section 6-10.7 above does not result in a resolution of the disputed matter, the parties may submit the dispute to arbitration before a single arbitrator after Final Completion of the Work. A demand for arbitration must be made within 30 days of completion of the mediation. The arbitrator will be a retired judge or an attorney with expertise in public works contracts. If the parties cannot agree on the appointment of the arbitrator within 30 days of arbitration being demanded, then the arbitration process will be terminated.

The arbitration hearing shall take place in Santa Barbara County. With the exception of the selection of the arbitrator, the arbitration process will be conducted as per California Code of Civil Procedure §1280 et seq. Discovery will be permitted as per the California Civil Discovery Act (Code of Civil Procedure §2016.010, et seq.). The arbitration award will be made under and in accordance with California law, supported by substantial evidence, and in writing.

The arbitrator's fee and any administrative fees will be borne equally by the parties to the arbitration, but each party to the arbitration will otherwise bear its own fees and costs.

The arbitration award will become binding unless one or more of the parties files a petition with the Santa Barbara County Superior Court pursuant to California Code of Civil Procedure §1285 et seq within 100 days after the arbitration award is issued by the arbitrator to correct or vacate the award. If the arbitration award becomes binding, it may be entered as a judgment in the Santa Barbara County Superior Court pursuant to a motion to confirm. A motion to correct or vacate the arbitration award shall be heard by the Superior Court de novo, without a jury, using the substantial evidence standard of review; as a result, the provisions of Code of Civil Procedure §1986.2 and §1286.6 do not apply to a motion to correct or vacate the arbitration award under this section, and as a result, the Superior Court can correct or vacate the arbitration award on any legal or equitable basis, including based on an error of law.

6-10.9 Writ of Mandate

If the arbitration process outlined in section 6-10.8 above does not occur, the Contractor may file a petition for writ of mandate in the Santa Barbara County Superior Court seeking judicial review of CVWD's decision or its designee within 90 days of the issuance of the decision pursuant to Code of Civil Procedure §1094.5.

6-10.10 Waiver of Jury Trial

By executing these contract documents, all parties agree to have disputes and/or controversies regarding the Project resolved in accordance with section 6-10 of this Agreement. Thus, all parties hereby waive their right to a jury trial for any disputes or controversies arising under this Agreement.

7.0 MEASUREMENT AND PAYMENT

7-2 LUMP SUM WORK

Subsection 7-2, Lump Sum Work, of the SSPWC is deleted in its entirety and replaced by the following:

Items for which quantities are indicated as "Lump Sum," "L.S.," "LS", or "Job" will be paid for at the price indicated in the Proposal. Such payment will be full compensation for all costs for labor, equipment, materials and plant necessary to furnish, construct and install the lump sum item of work, complete, in place, and for all necessary appurtenant work, including, but not limited to, all necessary cutting, patching, repair and modification of existing facilities, and clean up of site.

Contractor shall furnish three copies of a detailed schedule which breaks down the lump sum work into its component parts and cost for each part, in a form and sufficiently detailed as to satisfy Engineer that it correctly represents a reasonable apportionment of the lump sum. This schedule is subject to approval by Engineer as to the components into which the lump sum item is broken down, and the proportion of cost attributable to each component.

This schedule will be the basis for progress payments for the lump sum work and shall be submitted to the Engineer for review and revisions made to allow acceptance by the Engineer prior to submittal of the first progress payment request.

7-3.2 Partial and Final Payment

The third paragraph of Subsection 7-3.2 of the SSPWC, Partial and Final Payment, is deleted and is replaced by the following paragraph:

The Board will retain five percent (5%) of any progress payment as retention for the protection and payment of any person or persons, mechanics, subcontractor, or materialmen who shall perform any labor upon the Contract or work thereunder, and all persons who shall supply such person or persons or subcontractors with components and supplies for carrying on such work. Retention can also be used for correction of defective work if Contractor refuses to perform corrective work after being so directed by Board.

Withholding and disbursement of retention proceeds shall be done in accordance with Public Contract Code Section 7107.

Contractor's attention is drawn to Public Contract Code Section 7200, relating to retention proceeds and the furnishing of bonds by and for subcontractors.

A final balancing Change Order will be issued prior to submission of final pay request to incorporate all quantity variances from bid quantities into the final contract amount.

In accordance with Section 22300 of the California Public Contract Code, the Contractor will have the option of posting securities of equal or greater value in lieu of a cash retention.

A new paragraph is added to Subsection 7-3.2 of the SSPWC, Partial and Final Payment, to read as follows:

Progress payment paid by CVWD as contemplated herein, will be contingent upon the Contractor submitting, in addition to any additional documents, an updated Contract Schedule in the form prescribed by these Contract Documents. Failure of the Contractor to submit an acceptable updated Contract Schedule will result in CVWD withholding partial payment, without liability to CVWD, until such an acceptable updated Contract Schedule is submitted. Nothing herein will allow the Contractor to suspend or slow progress of the Work.

Final payment will not be made until punch-list items are satisfactorily completed, record drawings are satisfactorily completed, and all operations and maintenance manuals and other specified submittals are turned in and approved by the Engineer.

7-4 PAYMENT FOR EXTRA WORK

Subsection 7-4.2.3, Tool and Equipment Rental is modified where the second and third paragraphs are replaced with

“Regardless of Ownership, the rates to be used in determining the equipment usage costs shall not exceed those listed for the same or similar equipment in the California State Department of Transportation publication of Labor Surcharge and Equipment Rates effective for the period of usage.”

Subsection 7-4.3.1 Work by the Contractor and 7-4.3.2 Work by the Subcontractor’s Mark Up, are deleted in their entirety and replaced by the following subsections:

7-4.3.1 Work by the Contractor

The following percentages will be added to the Contractor's costs and will constitute the markup for all overhead and profits.

- 1) Labor..... 20%
- 2) Materials 15%
- 3) Equipment Rental 15%
- 4) Other Items and Expenditures 15%

To the sum of the costs and markups provided for in this subsection, 1 percent may be added as compensation for bonding.

7-4.3.2 Work by Subcontractor’s Markup

When all or any part of the extra work is performed by a Subcontractor, the markup established in 3-3.2.3(a) will be applied to the Subcontractor's actual cost of such work. A markup of 5 percent on the subcontracted portion of the extra work may be added by the Contractor.

7-4.4 Daily Reports

Change the third sentence of subsection 7-4.4, Daily Reports, to read:

“Failure to submit the daily report by the close of the next working day shall waive the Contractor’s right to payment for extra work for that day.”

8 FACILITIES FOR AGENCY PERSONNEL

8-1 GENERAL

This Section is deleted – no facilities are required for CVWD personnel.

100-1 TERMINATION OF AGENCY LIABILITY

Before receiving final payment, the Contractor will execute a “Release on Contract” form which will operate as, and will be a release to CVWD, the Board, and each member of the Board from all claims and liability to the Contractor for anything done or furnished for, or relating to, the work or for any act of neglect of CVWD of any person relating to or affecting the work, except the claim against CVWD for the remainder, if any there be, of the amounts kept or retained as provided in the Standard Specifications and except for any unsettled claims listed on said form which have been filed in compliance with the requirements for making claims.

SECTION 402 UTILITIES

402-1 LOCATION

Paragraph 402-1.1 General

Add the following wording to the first paragraph:

The Board does not guarantee the accuracy or completeness of this information and it is to be understood that other above-ground and underground facilities not shown on the drawings may be encountered during the course of the work. In any case, existing minor lines are not indicated.

402-2 PROTECTION

The following subsections are added to Subsection 402-2 of the SSPWC.

If the Contractor does not perform the potholing and notify the Engineer of any conflicts sufficiently in advance (minimum 5 working days) to allow appropriate design revision to accommodate conflicts, claims for delay by the Contractor for the changed condition will be denied by the District.

402-2.1 NOT USED

402-2.2 Maintenance of Service

The Contractor shall maintain service of water, sewer, power, gas, telephone and cable TV to all existing users. The Contractor shall install all piping, conduit, wire, pumps and other appurtenances as required for temporary service connections required to maintain service to existing users and shall include this cost in the bid.

402-4 RELOCATION

The following subsection is added.

402-4.1 NOT USED

402-5 DELAYS DUE TO UTILITY CONFLICTS

The following paragraphs are added to Subsection 402-5 of the SSPWC.

Actual loss, as used in this Subsection, will be understood to include no items of expense other than idle time of equipment and necessary payments for idle time of workers, cost of extra moving of equipment, and cost of longer hauls.

The following subsection is added to Subsection 402-5 of the SSPWC.

402-5.1 Calculating Idle Time

Equipment idle time will be calculated in accordance with Subsection 7-4.2.3 and based upon the actual normal working time during which the delay condition exists, but in no case will exceed 8 hours in any one day. The days for which compensation will be paid will be the calendar days, excluding Saturdays, Sundays and legal holidays, during the existence of the delay. Worker idle time will be calculated in accordance with Subsection 7-4.2.1.

END OF SECTION

SECTION C - SPECIAL PROVISIONS – TECHNICAL

SECTION 900 - GENERAL

900-1 DESCRIPTION OF BID ITEMS

A. Compensation for the work described in the following items shall include all costs for **completed work in-place as deemed acceptable by CVWD** including furnishing of all materials, tools, equipment, supplies, transportation, facilities, labor, supervision, coordination with the Engineer and other contractors and means and methods to perform the work required by the Contract Documents.

1. Payment for Bid Item No. 1 shall be made on a Lump Sum basis for Mobilization and shall consist of preparatory work and operations, including but not limited to those necessary for the movement of personnel, equipment, supplies, and incidentals to and from the project site. Mobilization shall include solicitation of pavement markings from utility company representatives indicating estimated locations of underground utilities, using the USA 811 process. Mobilization shall additionally include insurance, bonding, the establishment of any temporary facilities (not covered as a separate bid item), the submittal (and re-submittal as necessary) of required documentation including a construction schedule, preconstruction videotaping, Safety and Health requirements, preparation, implementation and compliance with a Stormwater Pollution Prevention Program, dust control measures, a pre-construction meeting and responsibility for jobsite conditions. Mobilization shall include all aspects of preparation of, implementation of, and compliance with an encroachment permit not explicitly included in Bid Item 2 (Traffic Control Plan). Demobilization shall additionally include the removal of temporary facilities (not covered as a separate bid item) and final clean-up.

Any other costs of work in advance of construction operations or for completion of operations and vacating the site and not directly attributable to any specific bid item shall be included in the item Mobilization.

2. Payment for Bid Item No. 2 shall be made on a Lump Sum basis for the Encroachment Permit and Traffic Control Plan. This includes, but is not limited to, preparation and implementation of a traffic control plan that complies with requirements set forth by the City of Carpinteria's encroachment permit(s) requirements, applying for encroachment permit(s), coordinated with the City's Public Works Department executing requirements of the encroachment permit(s) and closing out encroachment permit(s).

3. Payment for Bid Item No. 3 shall be made on a Unit Price basis for potholing required high priority locations within the City of Carpinteria's Downtown "T" Area as shown in Attachment B – Pothole Location Map. This includes, but is not limited to, excavation at the appropriate location, recording required information regarding the discovered utility, and back filling the excavated pothole per these specifications and the encroachment permit(s).
 4. Payment for Bid Item No. 4 shall be made on a Unit Price basis for potholing required high priority locations that are **not within** the City of Carpinteria's Downtown "T" Area as shown in Attachment B – Pothole Location Map. This includes, but is not limited to, excavation at the appropriate location, recording required information regarding the discovered utility, and back filling the excavated pothole per these specifications and the encroachment permit(s).
 5. Payment for Bid Item No. 5 shall be made on a Unit Price basis for potholing medium priority locations within the City of Carpinteria's Downtown "T" Area as shown in Attachment B – Pothole Location Map. This includes, but is not limited to, excavation at the appropriate location, recording required information regarding the discovered utility, and back filling the excavated pothole per these specifications and the encroachment permit(s) . .
 6. Payment for Bid Item No. 6 shall be made on a Unit Price basis for potholing medium priority locations that are **not within** the City of Carpinteria's Downtown "T" Area as shown in Attachment B – Pothole Location Map. This includes, but is not limited to, excavation at the appropriate location, recording required information regarding the discovered utility, and back filling the excavated pothole per these specifications and the encroachment permit(s).
- B. All work specified in the Contract Documents shall be included in the Bid Price. If required work is not specifically listed then its costs shall be included in the item above that most closely fits the work category.

900-2 RECORDING EXISTING CONDITION

900-2.1 General

A minimum of one week prior to start of construction, the Contractor shall video all areas where construction is to take place and all haul routes. Such video data shall be provided to the Engineer before construction commences. This data shall serve as a record of the existing conditions for disputes arising from restoration, and should therefore cover the construction area, site access and staging areas in sufficient detail to clearly depict details of existing conditions. The video data shall be provided on CD or DVD media in a common format. All video data shall be indexed and catalogued in such a manner that each photographed area is readily identifiable, and shall also indicate the date and time (hour, minutes) on which the

photograph was made. The Contractor shall also video any unusual conditions encountered during construction that are not already a matter of photographic record. In any areas where existing conditions cannot be determined by means of video data, the area shall be restored as approved by CVWD at Contractor's expense. All video data shall become the property of the CVWD.

900-2.2 Measurement and Payment

Measurement for providing video data shall be the same as for Mobilization and payment shall be included in the contract lump sum price for Mobilization.

900-3 NOT USED.

900-4 NOT USED.

900-5 TRAFFIC CONTROL

900-5.1 General Requirements

All work required for maintaining and controlling traffic during the construction period shall conform to the applicable provisions of the SSPWC as modified herein and the City of Carpinteria encroachment permit conditions. All such work shall additionally conform to the "Traffic Manual" issued by the State of California, Department of Transportation (Caltrans) and the "Work Area Traffic Control Handbook," published by Building News, Inc. In the event of any conflict the City of Carpinteria encroachment permit conditions shall prevail.

All construction work and traffic control shall be scheduled and constructed to provide for a minimum of inconvenience and a maximum of safety to the public vehicular and pedestrian traffic.

The Contractor shall be responsible for the protection of vehicular and pedestrian traffic until the work called for in the Standard Specifications, and these Special Provisions has been accepted by CVWD.

The Contractor shall notify CVWD of intent to begin work at least five working days before work is to begin. The Contractor shall cooperate with CVWD relative to handling traffic through the area and shall make all arrangements relative to keeping the working area clear of parked vehicles.

Contractor's equipment and personal vehicles of the Contractor's employees shall not be parked on the traveled way nor on any section where traffic is restricted at any time.

During any period when two-way traffic on a public street is not provided, the Contractor shall employ flaggers to control traffic through the construction zone.

Publicly accessible excavations shall be covered at the end of each working day.

The Contractor shall notify CVWD of any operation that will affect two-way flow of traffic in excess of five minutes for every half hour of working time, at least two working days in advance of such operation.

900-5.2 Construction Signing

Barricades and warning devices shall be provided by the Contractor to delineate the edge of traversable road and shall conform to the State of California, Department of Transportation "Traffic Manual," Chapter 5, hereinafter referred to as the Traffic Manual. Barricades shall be installed around all open traffic areas when no work is in progress.

900-5.3 Access

Access to street intersections, public and private parking lots, commercial businesses, residences, and other public and private properties must be maintained at all times. At least 72 hours in advance of starting any work that may affect the access to private properties, the Contractor shall provide written notice to such property owners. Vehicular access to and from commercial and residential driveways and parking lots shall be maintained at all times, except when performing items of work which cannot be accomplished without access restriction.

When access must be restricted, as determined by the General Manager, it shall occur only for the time period required to accomplish the particular item of work.

900-5.4 Restrictions on Closure of Traffic Lanes

- A. All traffic lanes shall be open for public use on the days and at the time specified below (see Caltrans permit for more restrictive conditions):
 - 1. Saturdays, Sundays and legal holidays: from 12:01 A.M. to 11:59 P.M.
 - 2. Fridays and any day preceding a legal holiday: from 3:00 P.M. to 11:59 P.M.
 - 3. All days not covered in 1 and 2 above:
7:00 A.M. to 9:00 A.M. and
4:00 P.M. to 6:00 P.M.
 - 4. Non-construction hours: all hours when the Contractor's employees are not physically present at the construction site actively performing contract work.
- B. On those days and hours when closure of traffic lanes is not prohibited under the provisions of the preceding subparagraph A, no more than one lane may be closed at any time during construction hours.

900-5.5 Temporary Guide Markers

Temporary guide markers shall be either portable delineators or fluorescent traffic cones and shall conform to these Special Provisions. Only one type of temporary guide marker shall be used at any one time.

Temporary guide markers shall be placed at all locations shown on the traffic control plans and at such locations as directed by the Engineer.

Temporary guide markers shall be left in place at their designated locations; maintained, repaired and replaced as required until their removal is approved by the Engineer.

If the temporary guide markers are damaged, or are not in an upright position, for any reason, said markers shall immediately be replaced, or restored to their original locations in an upright position, by the Contractor, 24 hours per day, 7 days per week for as long as required by CVWD.

900-5.6 Portable Delineators

Portable delineators shall conform to Section 12-3.04 of the State Standard Specifications.

The portable delineators shall be spaced as necessary for proper delineation; however, in no case shall the spacing between portable delineators exceed 25 feet on tangents or 10 feet on curves.

900-5.7 Fluorescent Traffic Cones

Fluorescent traffic cones shall be new or reconditioned, and of good commercial quality flexible material suitable for the purpose intended. The outer section of the portion above the base of the cone shall be a highly pigmented fluorescent orange polyvinyl compound. The overall height of the cone shall be at least 28 inches. The base shall be of sufficient weight and size or shall be anchored in a manner such that the traffic cone will remain in an upright position.

The fluorescent traffic cones shall be spaced as necessary for proper delineation; however, in no case shall the spacing between fluorescent traffic cones exceed 25 feet on tangents or 10 feet on curves.

900-5.8 Traffic Control Plans

See City of Carpinteria encroachment permit conditions.

900-5.9 Measurement and Payment

Measurement for traffic control shall be the same as for Compliance with City of Carpinteria Encroachment Permit Conditions.

Payment shall be included in the contract lump sum price for Compliance with City of Carpinteria Encroachment Permit Conditions. Such payment shall be considered full compensation for all labor, material, tools, and incidentals required to provide and implement the Traffic Control Plan.

900-6 SAFETY AND HEALTH REQUIREMENTS

900-6.1 General

In accordance with the requirements of the O.S.H.A. Regulation of Construction, the Contractor shall provide and require the use of personal protective and lifesaving equipment for all persons working in or about the project.

900-6.2 Head and Face Protection and Respiratory Devices

Such equipment shall include protective helmets conforming to the requirements of ANSI Z89.2-1971 which shall be worn by all persons at all times while in the vicinity of the work. In addition, workers engaged in or near the work area during sand blasting shall wear eye and face protection devices meeting the requirements of ANSI Z87.1-1968 and air purifying half-mask or mouth piece respirator with appropriate filter.

900-6.3 Ventilation

Where ventilation is used to control potential exposure to workers as set forth in Section 1910.94 of the O.S.H.A. Regulations for Construction, ventilation shall be adequate to reduce the concentration of the air contaminate to the degree that a hazard to the workers does not exist. Method of ventilation shall meet the requirements set forth in ANSI Z9.2-1960.

900-6.4 Confined Space Entry

Contractor shall submit a confined space entry program and permit for entry into all qualifying areas in accordance with SSPWC Section 7-10.4.4, Confined Spaces.

900-6.5 Temporary Ladders and Scaffolding

All temporary ladders and scaffolding shall conform to the applicable requirements of Subpart L, Section 1926.4 5 and 1926.451 of the O.S.H.A. Regulations for Construction.

900-6.6 Measurement and Payment

Measurement for Safety and Health Requirements shall be the same as for Mobilization.

Payment shall be included in the contract lump sum price for Mobilization. Such payment shall be considered full compensation for all labor, material, tools, and incidentals required to provide and implement Safety and Health Requirements.

900-7 NOT USED.

900-8 NOT USED

900-9 NOT USED.

END OF SECTION

SECTION 1000 – UNDERGROUND UTILITY INVESTIGATION

PART 1 - GENERAL

1.1 SUMMARY

- A. This specification covers the requirements for vacuum excavation, locating and documenting existing utilities, backfilling, and repair of the asphalt or concrete pavement for underground exploratory potholing.

1.2 REQUIREMENTS

- A. Contractor must prepare a traffic control plan and obtain an encroachment permit from the City of Carpinteria (City) prior to beginning Work. Work performed within the City right-of-way shall be performed in accordance with requirements and provisions of the encroachment permit issued by the City and Section 900-5 of the General Conditions. Where there is a conflict between these Specifications and those of the City, the City's provisions shall take precedence.

1.3 QUALITY ASSURANCE

- A. Perform Work in accordance with the 2018 Standard Specifications for Public Works Construction "The Greenbook".

1.4 SUBMITTALS

- A. 1- Sack Slurry materials shall be submitted for review and approval, including but not limited to supplier's name, ready-mix plant information, mix design, aggregate type and quality and general manufactures' data.
- B. Hot mix asphalt design data including but not limited to, aggregate gradation, performance grade oil type etc.
- C. Completed Pothole Information Forms documenting the general location, thickness of the existing pavement, utility type, pipe size and material, utility owner, depth to top of utility or encasement, cross sectional layout of utility, and picture of located utility. All above information shall be provided to the CVWD and pertinent information linked to a specific survey nail marker

PART 2 - PRODUCTS

2.1 CEMENT SAND SLURRY FOR BACKFILL

- A. Cement sand slurry for backfill in paved areas shall be slurry cement backfill is to conform to Section 201-6, "Controlled Low Strength Material (CSLM)," of the Standard Specifications for Public Works Construction (Standard Specifications). The class of concrete for slurry cement backfill is 100-E-100.

2.2 ASPHALT CONCRETE

- A. Asphalt Concrete: Asphalt concrete materials are to conform to Section 203-6, "Asphalt Concrete," of the Standard Specifications. Combined aggregate gradation is to be C2 (Dense Medium). Asphalt binder material to be mixed with aggregate is to be PG 64-10 paving asphalt conforming to Section 203-1, "Paving Asphalt," of the Standard Specifications. Percentage of asphalt binder for the combined aggregate gradation is to conform to Section 203-6.4.4, "Composition and Grading," of the Standard Specifications.

2.3 PRIME AND TACK COAT

- A. Tack Coat: Prime coat material to be applied on aggregate base surfaces shall conform to Section 302-5.3, "Prime Coat," of the Standard Specifications. Tack coat material to be applied on existing pavement surfaces shall conform to Section 302-5.4, "Tack Coat," of the Standard Specifications.

PART 3 - EXECUTION

3.1 POTHOLE EXCAVATION

- A. Conform to the excavation requirements listed in this section.
- B. Coordinate with appropriate utility owners to determine whether utility staff shall be present onsite during excavation. Coordinate appropriate excavation methods with each utility.
- C. Pothole to be accomplished through the use of vacuum excavation only, unless otherwise specified by specific utilities.
- D. Locate utility 1-foot deeper than anticipated and 2 feet to the left and right of the marked utility. If utility cannot be found, stop excavation and contact the appropriate utility owner for consultation and remarking.
- E. All spoils from vacuum excavation shall be disposed of off-site. No water shall be allowed to flow into storm drains or natural drainage courses.
- F. Contractor shall be solely and directly responsible to the providers of such utilities and services for any damage, expense, loss, inconvenience, delay, suits, actions, or claims, which may result from the construction operations.
- G. In the event of interruption to utility services as a result of accidental breakage due to construction operations, Contractor shall promptly notify the utility and CVWD. Contractor shall cooperate with said provider in the restoration of service as promptly as possible and bear all costs of repair.

3.2 CEMENT SAND SLURRY BACKFILL

- A. Place sand-cement slurry backfill in a uniform manner that will prevent voids in or segregation of the material. Remove foreign material that falls into the excavation or trench. No materials shall be placed over the slurry cement backfill for minimum of four hours after placing the sand-cement slurry.

3.3 PAVEMENT RESTORATION

- A. Pavement restoration shall be in accordance with the provisions of the encroachment permit.
- B. Clean area in preparations for application of hot-mix asphalt. Remove any loose fragments and debris from the area providing a solid base. Square up the pothole sides and extend at least 1-ft beyond the limit of the potholed area to tie into existing pavement.
- C. The City construction standard for asphalt concrete pavement replacement is Case I of Standard Plan 133 as provided in Attachment A. Case I is a full depth asphalt concrete pavement replacement.
- D. For concrete pavement replacement, a copy of the attached Standard Plan 132 is to be used. Further, concrete materials are to conform to Section 201, "Concrete, Mortar, and Related Materials," of the Standard Specifications.
- E. Apply tack coat to all vertical surfaces of existing pavement; to curbs, gutters, and construction joints against which asphalt concrete will be placed; to pavements to be surfaced; and where specified at the approximate rate of 0.05 gallons per square yard. Application shall be in accordance with Section 302-5 of SSPWC.
- F. Compact using a vibratory plate compactor or a single-drum vibratory roller. Final elevation shall match existing surface. The asphalt should be compacted in lifts no more than 3 in. thick.

3.4 DOCUMENTING UTILITY LOCATION

- A. Each pothole location shall be marked, identifying the horizontal alignment of the utility, with a survey nail over the potholed location with a unique identifier.
- B. Use pothole information form found in Attachment C to document required information for each buried utility found.

END OF SECTION

**ATTACHMENT A – CITY OF CARPINTERIA ENCROACHMENT PERMIT APPLICATION
FORMS AND STANDARDS**



Downtown "T" Encroachment Guidelines

City of Carpinteria



The City of Carpinteria regulates public right-of-way encroachments through Chapter 12.08 of the Carpinteria Municipal Code. The provisions of the Carpinteria Municipal Code establish the authority and process for allowing certain types of encroachments that are determined to be necessary or beneficial to the public interest and can be conducted in a manner that will not jeopardize public health and safety. In order to carry out the provisions of the Carpinteria Municipal Code, These guidelines will be adopted by the City Council and updated from time to time.

Public Works Department
5775 Carpinteria Avenue
Carpinteria, CA 93013

Phone: (805) 684-5405 ext. 445
Fax: (805) 684-5304

Encroachment Defined:

The City defines an encroachment as any item, good, material or merchandise placed on a City street or right-of-way. For the purposes of these guidelines, the encroachments addressed are those of a commercial nature that occur near or adjacent to the storefronts of businesses in the Downtown "T."

Downtown "T" Area Map:

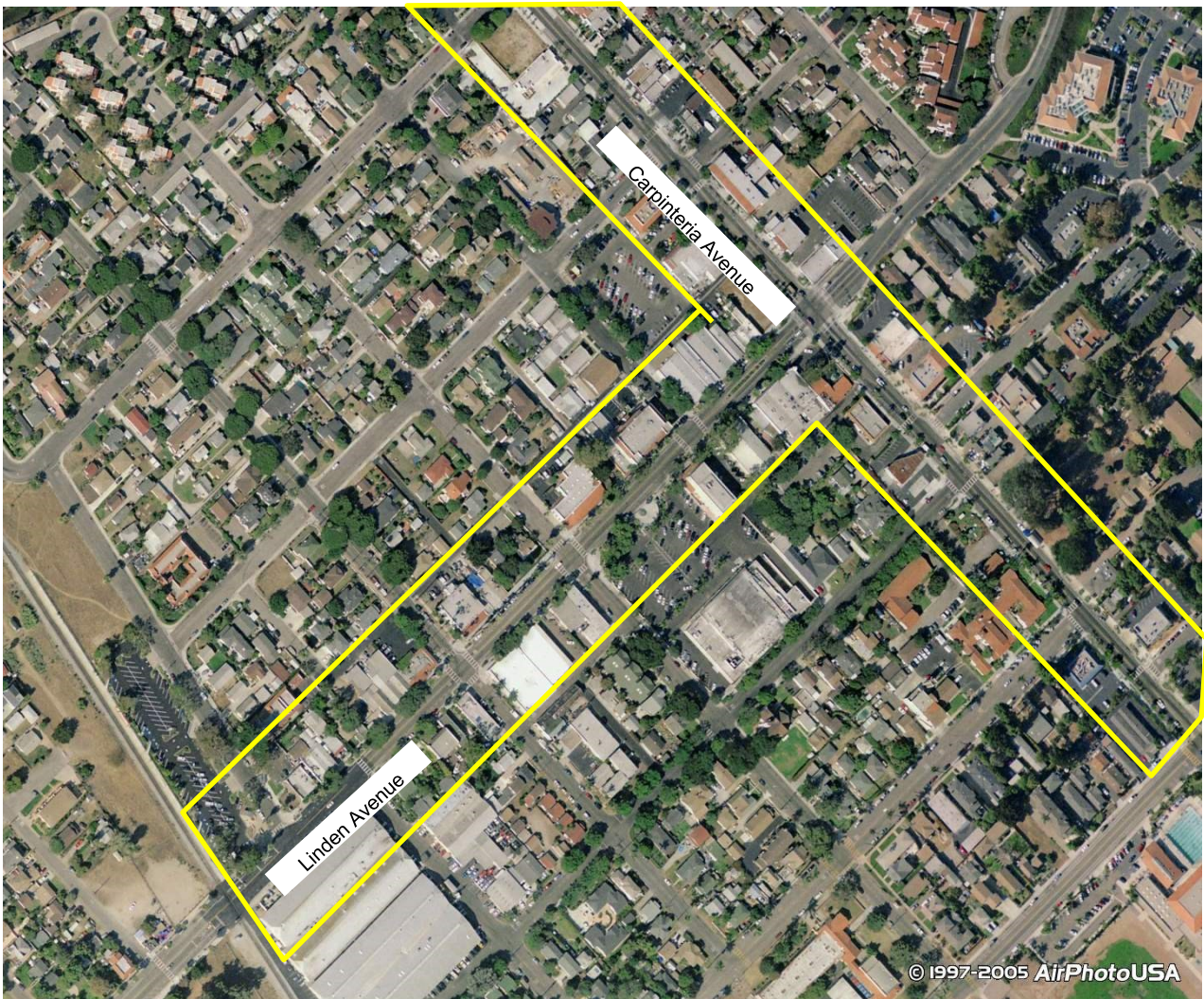

*Businesses in boundaries of Downtown "T" can apply.

Purpose:

The purpose of the Downtown “T” Encroachment Guidelines is to promote safe and attractive use of the public areas in the Downtown District. The City also aims to maintain and preserve existing public facilities and properties. These guidelines are intended to assist applicants and business owners in establishing attractive and safe encroachments that benefit both the Downtown business community and the citizens that enjoy those public spaces.

Organization:

These guidelines are organized as follows:

- **General Guidelines**
- **Location and Dimensions**
- **Maintenance and Operational Standards**
- **Colors and Materials**
- **Outdoor Displays**
- **Umbrellas and Outdoor Furniture**
- **Planters and Landscaping**
- **Other Types of Encroachments**
- **Permit Holder Requirements**

The following sections include references to the Carpinteria Municipal Code and General Plan. All applicable policies, standards and guidelines are shown in italics.

GENERAL GUIDELINES

The City's interest in reviewing applications for encroachment permits relates to the safety and well being of the public and the promotion of the Downtown as a vital and attractive pedestrian district. The City's goal is to maintain the highest standards of accessibility and safety while achieving an attractive and functional design. In general, allowed encroachments should compliment public use and improvements. In no case shall encroachments be permitted which serve to exclude the public from any public sidewalk or street.

Items permitted to encroach in the City right of way shall comply with all requirements of the Carpinteria Municipal Code and General Plan. The City will deny any Encroachment Permit that it determines does not comply with these guidelines or any other standard or regulation set forth by the City.

Location and Dimensions

Encroachments may be allowed where it can be determined by the City that the encroachment would not result, individually or cumulatively, in a narrowing of the sidewalk such that important functional attrib-



Figure 1 - Sidewalk café located near building to allow safe pedestrian access.

utes of the Downtown, (e.g., ability of pedestrians to stroll side-by-side and to pass comfortably for significant stretches, lingering and window-shopping) are not jeopardized. The location and dimensions of any item located in a public place shall meet these minimum guidelines and applicable local, state, and/or federal law or regulation.

- ^ **DEG1** - Encroachments shall be allowed so as to maintain a clear path of no less than six feet. The City

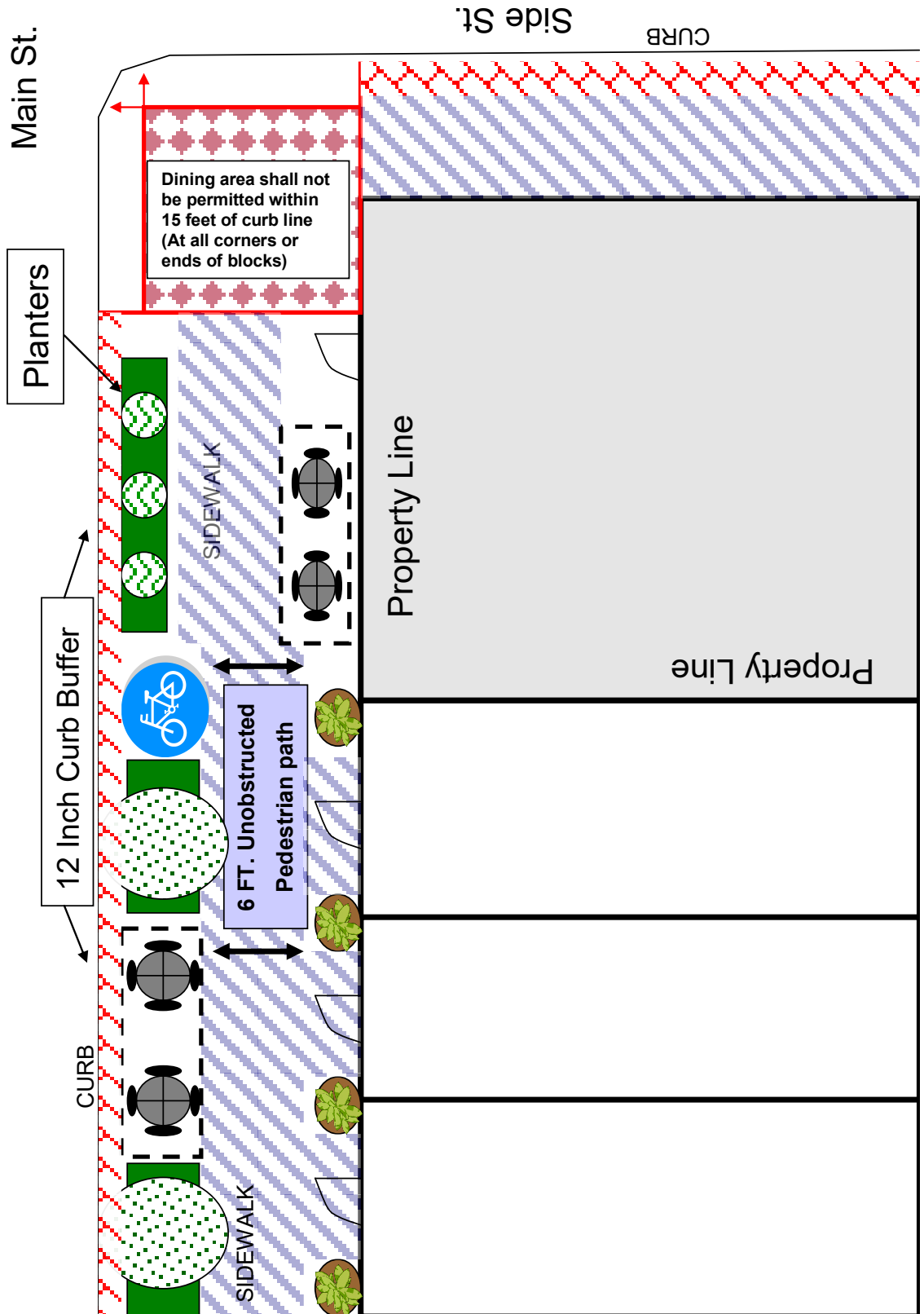

Figure 2 - Example of sidewalk café that respects the pedestrian pathways required

Manager may permit paths of travel of no less than four feet in instances where safe access can be determined. (See Figure 1)

- ^ **DEG2** - Encroachments shall not block safe access to businesses, parking spaces, bike stalls, or other spaces required by local, state or federal building or safety codes.
- ^ **DEG3** - Encroachments shall not encroach into the areas near corners of sidewalks or where crosswalks are present. This area shall be defined with a 15 foot area, beginning near the crosswalk or curb cuts. (See Figure 2)
- ^ **DEG4** - Tables shall not exceed 42 inches in width at the greatest dimension.
- ^ **DEG5** - Chairs shall not extend into the required accessible walkway at any time. Chairs must be at a scale appropriate to the size of the table or space available for seating.
- ^ **DEG6** - Portable outdoor heating devices are prohibited. Permanently mounted heating devices shall be reviewed by the Public Works Director



Figure 3 - Table, chairs and umbrella constructed of durable painted metal.



Figure 4 - Table, and chairs constructed of durable painted material

for safety and aesthetics and require separate building permit review.

- ^ **DEG7**— The Public Works Department may require the Architectural

Review Board to review any items placed in the City Right-of-Way that are not clearly consistent with these guidelines.

Maintenance and Operational Standards

- ^ **DEG8** - Maintenance of sidewalk encroachments shall be the sole responsibility of the permit holder.
- ^ **DEG9** - Any item permitted to be placed in the City Right of Way shall be maintained in a safe manner so as not to obstruct pedestrian access to public sidewalks, access ramps or doorways. Movable items, like chairs, shall be positioned to prevent obstruction of access routes at all times. The permitted item shall be, if moved by patrons, relocated to the appropriate location at all times.
- ^ **DEG10** - All materials shall be well maintained without stains, rust, tears or discoloration. Materials that show signs of significant wear/age shall be replaced.
- ^ **DEG11** - Umbrellas shall be con-

structed of durable fade resistant materials.

Colors and Materials

The types of materials placed on City sidewalks shall portray a well maintained and aesthetically appealing streetscape. The variety of uses that exist in the Downtown require a cohesive Guideline of allowed materials, colors and variation of items permitted in the common commercial area.

- ^ **DEG12** - All items located on the public sidewalk shall be constructed of durable materials appropriate for use in the public rights-of-way. Folding chairs, light weight materials, deteriorated, U.V. damaged, splintered or other similar furniture will not be approved or placed in the rights-of-way. Sealed or painted metal or wood tables are recommended.
- ^ **DEG13** - Permitted encroachments shall be complimentary in material, color and design to the buildings they serve and are adjacent to.
- ^ **DEG14** - Table cloths, umbrellas and similar materials used as part of an encroachment, shall be clearly de-

scribed in the project application (material samples may be required). All materials shall be painted, stained, etc., in a solid color; stripes and patterns are discouraged.

- ^ **DEG15**– Street furniture shall not contain signs, advertising, or logos. (See Figure 5)

Outdoor Displays

- ^ **DEG16** - Sales racks shall not be permitted within the City right of way.
- ^ **DEG17** - Outdoor displays shall be limited to single items or object displays or a few examples of items or goods sold in the store and must comply with all other standards of these guidelines.

Umbrellas and Outdoor Furniture

- ^ **DEG18** - Umbrella shades shall have approved solid colors. Patterns and stripes are discouraged.
- ^ **DEG19** - Umbrellas shall be installed and maintained so as to provide pedestrian clearance by maintaining seven (7) feet of clearance from the sidewalk to the lowest edge of the um-

brella. Umbrellas shall not exceed a maximum height of nine (9) feet from the base to the top portion of the pole.

Planters and Landscaping

- ^ **DEG20** - The use of pots and other planters should be kept to a minimum and used against buildings to accent openings. Planters shall not be used to define seating areas or otherwise cordon off public sidewalk for private use.
- ^ **DEG21**—Planters shall be of a variety and maintained so as to not drain onto the sidewalk or street.
- ^ **DEG 22** - Plant material shall be of high quality and shall be maintained in viable condition at all times.
- ^ **DEG23** - Debris or litter caused by planters or nearby landscaping shall be maintained or cleaned by the responsible business or property owner. Debris, stains or litter shall be cleaned or removed by the responsible business or property owner.

- ^ **DEG24** - Planters and landscaping shall be trimmed to maintain the required six foot clearance required by DEG1.

Other Types of Encroachments

- ^ **DEG25** - Other types of encroachments, not anticipated in these guidelines, may be considered and permitted by the City, but must comply with the purpose and intent of these guidelines.

Annual Permit Holder Requirements

- ^ **Complete the appropriate Encroachment Permit Application and submit the appropriate application fees, and or renewal fees.**

- ^ **Description** - Detailed written description that includes the number, style and type of material to be included in the Downtown “T” Encroachment Permit.
- ^ **Diagram** - Scale drawing showing proposed Encroachments in relation to existing sidewalk, business frontage, parking, or landscape areas.
- ^ **Images** - Applicant shall provide photographs of the proposed material/furniture.
- ^ **Maintenance Agreement** - Applicant shall agree to maintain the area near the permitted area clean and free of all trash and litter. Applicant shall also maintain the sidewalk and trash containers provided by the City that serve the business.
- ^ **Trash Agreement** - Applicant shall empty the trash bins nearest their business to prevent overflow.
- ^ **Pedestrian Access** - Applicant shall maintain the required pedestrian access set forth by the permit, these guidelines or any other safe access requirements.
- ^ **Indemnification and Insurance** - Issuance of an encroachment permit shall be contingent upon the applicant signing the City indemnification/hold harmless agreement. The applicant shall also provide proof of insurance in accordance with Chapter 12.08 of the Carpinteria Municipal Code. Minimum coverage limits will be established by the City at the time of application.

City of Carpinteria, California

PUBLIC WORKS DEPARTMENT



DOWNTOWN “T” ENCROACHMENT PERMIT APPLICATION

Encroachment Type: Tables/Chairs Outdoor Displays Umbrellas/Outdoor Furniture
 Planters/Landscaping Other: _____

APPLICANT INFORMATION

Applicant Name: _____

Address: _____

Phone: _____ Email: _____

BUSINESS INFORMATION

Business Name: _____

Business Address: _____

Business Phone: _____ Hours of Operation: _____

Proprietor Name: _____ Phone: _____

Please provide a detailed description of all materials to be placed upon the City sidewalk in the table below. Please use additional sheets if the space provided below is not large enough.

	Type of Material or Item	Location of Item	Dimensions	Number of Items
1				
2				
3				
4				

SITE PLAN/PHOTOGRAPHS

- A detailed site plan on 8 ½" x 11" paper shall be submitted with application. All sidewalk obstructions shall be noted with dimensions clearly shown. Site plan shall show the required clear pathway for pedestrian access and any other requirements set for by the City. *Additional requirements can be found in the "Downtown Encroachment Guidelines."*
- Applicant shall provide photographs of the proposed area and proposed materials/furniture.

CONDITIONS OF APPROVAL

This application for permit to install tables and chairs or other materials, as part of an established restaurant, café or shop along Linden and or Carpinteria Avenue (Downtown "T") in the public right-of-way, is subject to the provisions as required by the City of Carpinteria Municipal Code § 12.08 *Street and Sidewalk Encroachments* and the *Downtown Encroachment Permit Guidelines*.

CLEANUP AND TRASH REMOVAL AGREEMENT

Sidewalk areas adjacent to permitted tables must be kept clean and free of debris at all times. The City empties the street-side trash bins adjacent to downtown businesses multiple times a week. **Businesses with outdoor dining facilities are required to empty street-side trash bins whenever necessary to prevent over flow of trash and debris.** These trash receptacles are provided by the City for public use and are not intended to serve outdoor cafés. **Outdoor dining facilities shall clear all food and related trash to trash receptacle within the business rather than the City trash bins located for public use.**

By obtaining an encroachment permit to use the City sidewalk, you are agreeing to monitor and clean permitted area as necessary. Violations of this agreement may result in administrative warnings/citations from the Code Compliance Division in addition to revocation of permit and forfeiture of all fees.

Initial: _____

The provisions of the foregoing sentence shall not apply in any case where the easement for the facilities was in existence prior to the existence as such of the public right-of-way concerned herein. This includes the following:

- Permittee shall maintain the City public right-of-way clean and free of all trash and litter.
- Permit holders with outdoor dining facilities shall clear tables of trash and/or dishes within 5 minutes of customers exiting the area.
- Permittee agrees to remove/empty trash from nearby City trash receptacles as necessary to prevent over-flow regardless of whose trash it contains.**
- Permittee agrees to not block the public right-of-way with tables and chairs and/or merchandise in compliance with CMC §12.08 *Street and Sidewalk Encroachments* and agrees to maintain the minimum pathway width outlined in this permit at all times.
- Permittee agrees to use only umbrellas that do not contain any advertising, signs or prints.
- Permittee understands that failure to comply with these conditions may result in the termination of approval to use the public right-of-way, and that he/she will not be given a refund.

Permittee understands that any materials placed within the public right-of-way may require a permit and will contact the City prior to installation of any goods or materials in accordance to Carpinteria Municipal Code Chapter 12.

Additional Conditions:

Initial _____

INDEMNIFICATION AND INSURANCE REQUIREMENTS

In consideration of the granting of this annual permit, it is agreed by the applicant that the City of Carpinteria and any officer and/or employee thereof shall be saved harmless by the applicant from any liability and/or responsibility for any accident, loss or damage to persons or property, happening or occurring as the proximate result of any of the action undertaken under the terms of this application and the permit or permits which may be granted in response thereto, and that all of said liabilities are hereby assumed by the applicant. It is further agreed that if any facilities placed in the right-of-way for which this application is granted and approved as a permit, shall become incompatible with future travel by the general public, then the applicant or its assigns or successors will, either remove such facilities in cases where such removal is necessary or in cases where the use thereof has been or is to be abandoned, or in other cases, applicant or its assigns or successors will relocate such facilities at a location designated by the City.

Initial _____

Applicant shall provide a certificate of insurance with an additional insured endorsement (ISO form CG2012 or equivalent) of not less than one million dollars (\$1,000,000) combined single limit for both bodily injury and property damage naming the City of Carpinteria as an additional insured. The policy or policies shall also contain a provision that no termination, cancellation, or change of coverage for the insured or additional insured shall take effect until ten (10) days notice has been given in writing to the City Clerk of the City of Carpinteria.

PLEASE BE SURE YOUR APPLICATION IS COMPLETE!

Your application must contain the following items to be considered for approval:

- Completed permit application
- Application Fee (\$195/New or Modified, \$120/Renewal)
- Signed Standard Indemnification and Insurance Agreement
- Certificate of Insurance with Additional Insured Endorsement
- Detailed site plan
- Photographs of proposed area and furniture

By signing below, applicant agrees to the above terms and conditions.

Applicant Signature(s): _____ Date: _____

Applicant Printed Name: _____

Business Owner Signature(s): _____ Date: _____

Business Owner Printed Name: _____

OFFICE USE ONLY

FEE PAID: \$ _____ CHECK #: _____ CASH RECEIPT #: _____ DATE: _____

PERMIT ISSUANCE DATE: _____ PERMIT EXPIRATION DATE: _____

APPROVED BY: _____ DATE: _____

Public Works Director

City of Carpinteria, California



PUBLIC WORKS DEPARTMENT

Engineering Permit Application

Select all boxes that apply to your project

GRADING

Type _____

EXCAVATION

Type _____

CONSTRUCTION

Type _____

ENCROACHMENT

Type _____

OTHER

Type _____

For Official City Use Only

Date of Permit Application _____

Date of Permit Issuance _____ Date of Permit Expiration _____

List of Attachments _____

Required Bond Amount _____ City Account Number _____

Engineering Deposit Fee _____

Applicant Information

Full Name _____

Mailing Address _____

Phone _____ Alternate Phone _____

Contact Person _____ Email _____

Location of Work _____

Project Duration _____

Approximate Value of Work Items Listed \$ _____

Description of Work _____

Property Owner Information (If Applicable)

Full Name _____
 Mailing Address _____
 Phone _____ Alternate Phone _____
 Contact Person _____ Email _____
 Assessor's Parcel No. (APN) _____

Contractor Information

ATTENTION: All work shall be performed by a Class A- General Engineering Contractor with the license issued by the Contractors State License Board and in good standing. The Contractor shall maintain insurance in conformance with the Insurance Specifications for Engineering Permit.

Same as Applicant

Business Name _____
 Mailing Address _____
 Phone _____ Alternate Phone _____
 Contact Person _____ Email _____
 License Type _____ License No. _____
 Bonding Company _____ Bond Amount _____

Standard Conditions

The Permittee shall schedule a preconstruction conference with the City by calling (805) 684-5405 extension 445 at least two working days before the start of any work under this permit.

1. A copy of this permit shall be kept at the location of work at all times.
2. All work shall conform to the Standard Specifications for Public Works Construction latest edition, supplements, and errata thereto, written and promulgated by Public Works Standards, Inc., and additions and amendments by the City of Carpinteria. All work is subject to the Carpinteria Municipal Code.
3. All work shall be performed by a Class A- General Engineering Contractor with the license issued by the Contractors State License Board and in good standing.

4. The Permittee agrees to these Standard Conditions and special conditions incorporated herein permit. Deviation from any condition will result in revocation of this permit, unless otherwise approved by the City.
5. The Permittee acknowledges that the fee and/or deposit set for this permit is an estimate only, and that if the City's cost exceeds the deposit, the Permittee shall make additional payments as necessary to maintain a positive account balance.
6. The Permittee shall defend, indemnify, and save harmless the City, its officers, agents and employees from any and all claims, demands, damages, costs, expenses including attorney's fees, judgments or liabilities arising out of this permit or occasioned by the performance or attempted performance of the provisions hereof; including, but not limited to, any act or omission to act on the part of its agents or employees or other independent directly responsible to it; except those claims, demands, damages, costs, expenses including attorney's fees, judgments or liabilities resulting solely from the negligence or willful misconduct of the City.
7. The Permittee shall be responsible for providing convenience and safety to the public.
8. All improvements constructed under this permit shall be guaranteed for a period of one (1) year from the permit clearance date.
9. The work shall be inspected by the City. Any part of the work that is not inspected will be subject to removal at the expense of the Permittee.
10. Call 811 for Underground Service Alert of Southern California (Dig Alert) no less than two working days before the start of any excavation activities. This permit is not valid without a Dig Alert ticket.
11. The Permittee shall notify the Santa Barbara County Sheriff's Department and the Carpinteria-Summerland Fire Protection District at least 24 hours before the start of hauling operations or road closures.
12. The Permittee shall be responsible for protecting all survey monuments in place and resetting of any disturbed monuments by a Licensed Land Surveyor or Registered Civil Engineer authorized to practice land surveying as required by state law.
13. Permit for excavation only grants permission to excavate at the location stated herein this permit. Installation of or connection to underground utility facilities may require separate permits from the respective utility companies.
14. The Permittee shall immediately stop work in the event of discovering any archaeological resources and shall immediately notify the City. A qualified archaeologist, retained by the Permittee, will evaluate the situation and make recommendations to the City concerning the continuation of the work.
15. Issuance of this permit does not in any way constitute approval for work not related to this permit and/or work which requires issuance of a separate permit by other City departments, regulatory agencies, or utility companies before the start of such work.
16. The Permittee shall be responsible for protecting all existing improvements and shall restore, replace, or repair, at its own expense, any improvements damaged during the course of the work.
17. For earthwork operations including the grading, removal, replacement, placement, backfill, and compaction of soil materials shall be performed under the responsible charge of a Registered Geotechnical Engineer or Registered Civil Engineer qualified to practice geotechnical engineering as required by state law. A final soils engineering report of earthwork operations including tests and observations shall be submitted to the City prior to the issuance of a building permit.
18. Trenches and potholes shall be backfilled and compacted, and protected with steel covers before the end of the working day.
19. Construction activities that disturb one or more acres of land surface, or that are part of a common plan of development or sale that disturbs more than one acre of land surface shall comply with the NPDES

General Permit for Storm Water Discharges Associated with Construction and Land Disturbance Activities (Order No. 2009-0009-DWQ; NPDES No. CA000002) as amended.

20. The Permittee shall be responsible for controlling surface water run-on to and run-off from the location of work. Control of surface water shall be such that existing drainage patterns are not disturbed or altered to increase the amount and/or intensity of surface water run-off to adjacent properties, public right-of-way, and storm drainage facilities.
21. Dust control shall be in accordance with the Santa Barbara Air Pollution Control District rules and regulations. Dust palliative shall be implemented appropriate for the location of work including traffic conditions and climate. All earthwork loads to be hauled shall be covered.
22. Working hours shall be between 7:00 a.m. and 5:00 p.m. Monday through Friday. Lane closures will only be permitted between 9 a.m. and 4 p.m. Monday through Friday and with an approved temporary traffic control plan and public noticing.
23. Prior to beginning the work, the Permittee shall deliver written notice to each potentially affected property including business, resident, or occupant, as determined by the City. The notice shall contain a brief description of the work, work dates, and contact information of the Permittee's superintendent. The notice shall be delivered at ten (10) calendar days and again at two (2) working days prior to beginning the work. The notice shall be in the form of a door hanger made of index paper with the size of 14 inches by 4.5 inches. The notice shall be in English with translation in Spanish. If work does not occur on the work dates specified on the notice or if it is known that the work will not occur on the work dates specified, a revised notice shall be delivered as soon as the delay is known. The notice shall also be affixed to temporary No Parking signs.
24. Temporary No Parking signs shall be erected or placed at least twenty-four (24) hours prior to the effective time of such parking restriction.
25. Truck or haul route shall be approved by the City before the start of any hauling operations.
26. This permit shall expire and become null and void if the work authorized under such permit is not commenced within one hundred twenty (120) calendar days, completed within one year of the date of issue, or otherwise extended by the City.
27. Prior to final clearance of this permit, any outstanding City fees shall be paid in full. The Permittee continues to be responsible for all activity under this permit until final clearance of this permit.
28. The City reserves the right to revoke this permit without cause and at any time. Upon written revocation of this permit by the City, the Permittee shall promptly restore the location of work as determined by the City.
29. If the Permittee fails to perform the work to fulfill the permit, the City will perform the work at the expense of the Permittee.
30. The Permittee shall notify the City when work is completed. This permit is not completed until final clearance and all outstanding City fees are paid in full.

Applicant as PERMITTEE:

Signature

Date

For Official City Use Only

Issued By:

Public Works Director/City Engineer

Date

Final Clearance By:

Inspector

Date

INSURANCE SPECIFICATIONS FOR ENGINEERING PERMIT

Prior to the beginning of and throughout the duration of the Work, Contractor shall maintain insurance in conformance with the requirements set forth below. Contractor shall use existing coverage to comply with these requirements. If that existing coverage does not meet the requirements set forth here, it shall be amended to do so. Contractor acknowledges that the insurance coverage and policy limits set forth in this section constitute the minimum amount of coverage required. Any insurance proceeds available to City in excess of the limits and coverage required in this permit and which is applicable to a given loss, shall be available to City.

Contractor shall provide the following types and amounts of insurance:

1. **Commercial General Liability Insurance** using Insurance Services Office “Commercial General Liability” policy form CG 00 01 or the exact equivalent. Defense costs must be paid in addition to limits. There shall be no cross liability exclusion for claims or suits by one insured against another. Limits shall be no less than \$1,000,000 per occurrence for all covered losses and no less than \$5,000,000 general aggregate.

Contractor’s policy shall contain no endorsements limiting coverage beyond the basic policy coverage grant for any of the following:

- Explosion, collapse or underground hazard (XCU)
- Products and completed operations
- Pollution liability
- Contractual liability

Coverage shall be applicable to City for injury to employees of contractors, subcontractors or others involved in the Project. Policy shall be endorsed to provide a separate limit applicable to this project.

2. **Workers Compensation** on a state-approved policy form providing statutory benefits as required by law with employer’s liability limits no less than \$1,000,000 per accident for all covered losses.
3. **Business Auto Coverage** on ISO Business Auto Coverage form CA 00 01 06 92 including symbol 1 (Any Auto) or the exact equivalent. Limits shall be no less than \$1,000,000 per accident, combined single limit. If Contractor owns no vehicles, this requirement may be satisfied by a non-owned auto endorsement to the general liability policy described above. If Contractor or Contractor’s employees will use personal autos in any way on this project, Contractor shall provide evidence of personal auto liability coverage for each such person.
4. **Excess or Umbrella Liability Insurance** (Over Primary) if used to meet limit requirements, shall provide coverage at least as broad as specified for the underlying coverages. Any such coverage provided under an umbrella liability policy shall include a drop down provision providing primary coverage above a maximum \$25,000 self-insured retention for liability not covered by primary but covered by the umbrella. Coverage shall be provided on a “pay on behalf” basis, with defense costs payable in addition to policy limits. There shall be no cross liability exclusion precluding coverage for claims or suits by one insured against another. Coverage shall be applicable to City for injury to employees of Contractor, subcontractors or others involved in the Work. The scope of coverage provided is subject to approval of City following receipt of proof of insurance as required herein. Limits are subject to review but in no event less than \$1,000,000 per occurrence and aggregate.
5. **Course of Construction** insurance shall provide “all risk” coverage for the completed value of the Project. Policies shall contain the following provisions: (1) City shall be named as loss payee; and (2) the insurer shall waive all rights of recovery against the City. This insurance shall include coverage, but not by way of limitation, for all damage or loss to the Work and to appurtenances, to materials and equipment to be used on the Project while the same are in transit, stored on or off the Project site, to construction plant and temporary structures. The policy shall provide the Owner the right to utilize the facilities without termination of the policy until acceptance of the Project.

Such insurance may have a deductible clause not to exceed the below listed limits:

- Coverage for “Acts of God” in excess of five percent (5%) of Contract amount as defined in Sections 4150 and 4151 of the Government Code is subject to separate coverage if Bid Items for Act of God insurance are awarded.
- Flood and earthquake deductible shall not exceed five percent (5%) of the value at risk at the time of risk.
- All other perils: \$5,000.

Contractor and City agree as follows:

1. Contractor agrees to endorse the third party general liability coverage required herein to include as additional insureds City, its elected officials, employees, agents, consultants and volunteers using standard ISO endorsement No. CG 2010 with an edition date of 1985. Contractor also agrees to require all contractors, subcontractors, and any one else involved in any way with the Project contemplated by this Permit to comply with these provisions.
2. Any waiver of subrogation express or implied on the part of City to any party involved in this Permit, the Contract Documents or related documents applies only to the extent of insurance proceeds actually paid. City, having required that it be named as an additional insured to all insurance coverage required herein, expressly retains the right to subrogate against any parts for sums not paid by insurance. For its part, Contractor agrees to waive subrogation rights against City regardless of the applicability of any insurance proceeds, and to require all contractors, subcontractors or others involved in any way with the project(s) contemplated by this Permit, to do likewise.
3. All insurance coverage maintained or procured by Contractor or required of others by Contractor pursuant to this Permit shall be endorsed to delete the subrogation condition as to City, or to specifically allow Contractor or others providing insurance herein to waive subrogation prior to a loss. This endorsement shall be obtained regardless of existing policy wording that may appear to allow such waivers.
4. Insurance provided pursuant to these requirements is not intended by any party to be limited to providing coverage for the vicarious liability of City, or to the supervisory role, if any, of City. All insurance coverage provided pursuant to this or any other agreement (express or implied) in any way relating to City is intended to apply to the full extent of the policies involved. Nothing referred to here or contained in any agreement involving City in relation to the Project contemplated by this Permit is intended to be construed to limit the application of insurance coverage in any way.
5. None of the coverages required herein will be in compliance with these requirements if they include any limiting endorsement of this kind that has not been first submitted to City and approved of in writing.
6. All coverage types and limits required are subject to approval, modification and additional requirements by the City, as the need arises. Contractor shall not make any reductions in scope of coverage (e.g. elimination of contractual liability or reduction of discovery period) which may affect City's protection without City's prior written consent.
7. Proof of compliance with these insurance requirements, consisting of binders of coverage, or endorsements, or certificates of insurance, unless waived by the City, shall be delivered to City at or prior to the execution of this Permit. The Contractor shall, upon demand of the City, deliver to the City certified copies of such policy or policies of insurance and the receipts for payment of premiums. In the event such proof of any insurance is not delivered as required, or in the event such insurance is canceled at any time and no replacement coverage is provided, City has the right, but not the duty, to obtain any insurance it deems necessary to protect its interests under this or any other agreement and to pay the premium. Any premium so paid by City shall be charged to and promptly paid by Contractor or deducted from sums due Contractor, at City option.
8. Contractor agrees to endorse, and to require others to endorse, the insurance provided pursuant to these requirements, to require 30 days notice to City and the appropriate tender prior to cancellation of such liability coverage and notice of any material alteration, non-renewal or reduction in coverage limits of any such coverage, and to require contractors, subcontractors and any other party in any way involved with the project contemplated by this Permit to do likewise.
9. It is acknowledged by the parties of this Permit that all insurance coverage required to be provided by Contractor or any subcontractor, is intended to apply first and on a primary non-contributing basis in relation to any other insurance or self insurance available to City.
10. Contractor agrees to ensure that subcontractors, and any other party involved with the project who is brought onto or involved in the Project by contractor, provide the same minimum insurance coverage required of Contractor. Contractor agrees to monitor and review all such coverage and assumes all responsibility for ensuring that such coverage is provided in conformity with the requirements of this section. Contractor agrees that upon request, all agreements with subcontractors and other engaged in the Project shall be submitted to the City for review.
11. Contractor agrees that all layers of third party liability coverage required herein, primary, umbrella and excess, shall have the same starting and expiration date. Contractor agrees further that all other third party coverages required herein shall likewise have concurrent starting and ending dates.
12. Contractor agrees not to self-insure or to use any self-insured retentions or deductibles on any portion of the insurance required herein and further agrees that it shall not allow any contractor, subcontractor, Architect, Engineer or other entity or person in any way involved in the performance of work on the project contemplated by this Permit to self-insure its obligations to City. If contractor's existing coverage includes a deductible or self-insured retention, the deductible or self-insured retention must be declared to the City. At that time the City shall review options with the Contractor, which may include reduction or elimination of the deductible or self-insured retention, substitution of other coverage, or other solutions.

13. City reserves the right at any time during the term of the contract to change the amounts and types of insurance required by giving the Contractor ninety (90) days advance written notice of such change. If such change results in substantial additional cost to the Contractor, the City will negotiate additional compensation proportional to the increased benefit to City.
14. For purposes of applying insurance coverage only, all contracts pertaining to the Project will be deemed to be executed when finalized and any activity commences in furtherance of performance under this Permit.
15. Contractor acknowledges and agrees that any actual or alleged failure on the part of City to inform Contractor of non-compliance with any insurance requirement in no way imposes any additional obligations on City nor does it waive any rights hereunder in this or any other regard.
16. Contractor shall renew the required coverage annually as long as City, or its employees or agents face an exposure from operations of any type pursuant to this Permit. This obligation applies whether or not the agreement is canceled or terminated for any reason. The insurance shall include but not be limited to products and completed operations and discontinued operations, where applicable. Termination of this obligation is not effective until City executes a written statement to that effect.
17. Contractor agrees to waive its statutory immunity under any workers' compensation statute or similar statute, in relation to the City, and to require all subcontractors and any other person or entity involved in the Project contemplated by this Permit to do likewise.
18. Requirements of specific coverage features are not intended as limitations on other requirements or as a waiver of any coverage normally provided by any given policy. Specific reference to a given coverage feature is for purposes of clarification only as it pertains to a given issue, and is not intended by any party or insured to be all-inclusive.
19. Any provision in any of the construction documents dealing with the insurance coverage provided pursuant to these requirements, is subordinate to and superseded by the requirements contained herein. These insurance requirements are intended to be separate and distinct from any other provision in this Permit and are intended by the parties here to be interpreted as such.
20. All liability coverage provided according to these requirements must be endorsed to provide a separate aggregate limit for the Project that is the subject of this Permit and evidencing products and completed operations coverage for not less than two (2) years after issuance of a final certificate of occupancy by all appropriate government agencies or acceptance of the completed work by City.
21. Contractor agrees to be responsible for ensuring that no contract used by any party involved in any way with the Project reserves the right to charge City or Contractor for the cost additional insurance coverage required by this Permit. Any such provisions are to be deleted with reference to City. It is not the intent of City to reimburse any third party for the cost of complying with these requirements. There shall be no recourse against City for payment of premiums or other amounts with respect thereto.
22. Insurance procured pursuant to these requirements shall be written by insurers that are admitted carriers in the State of California and with an A.M. Best rating of A- or better and a minimum financial size of VII.
23. Any policy of insurance procured pursuant to these requirements shall be an "occurrences" policy.
24. The above insurance coverage shall not limit the indemnification obligations of Contractor as provided in the Contract Documents and the failure to maintain the required coverages shall constitute a material breach of this Permit.

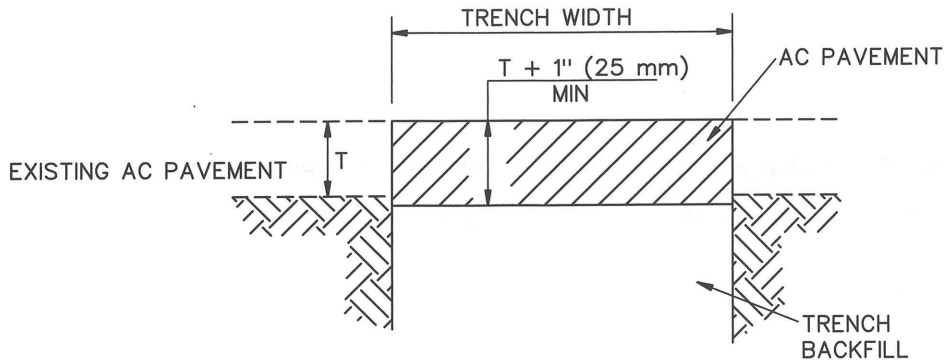

CASE I – AC PVMT ON TRENCH BACKFILL

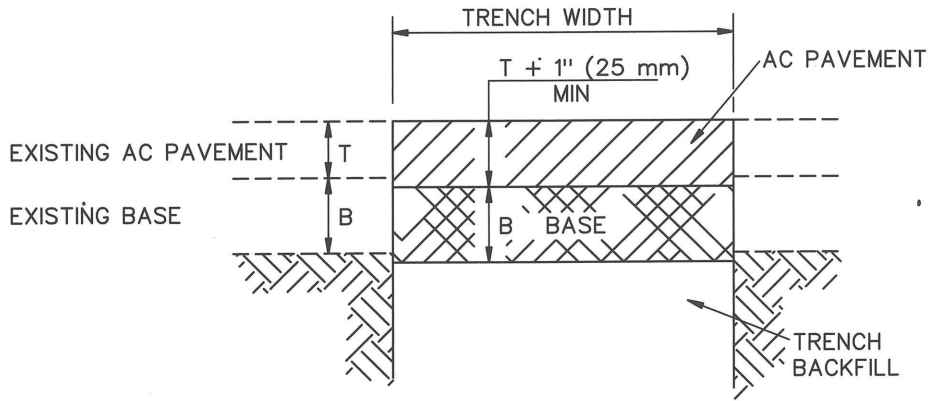

CASE II – AC PVMT ON BASE MATERIAL

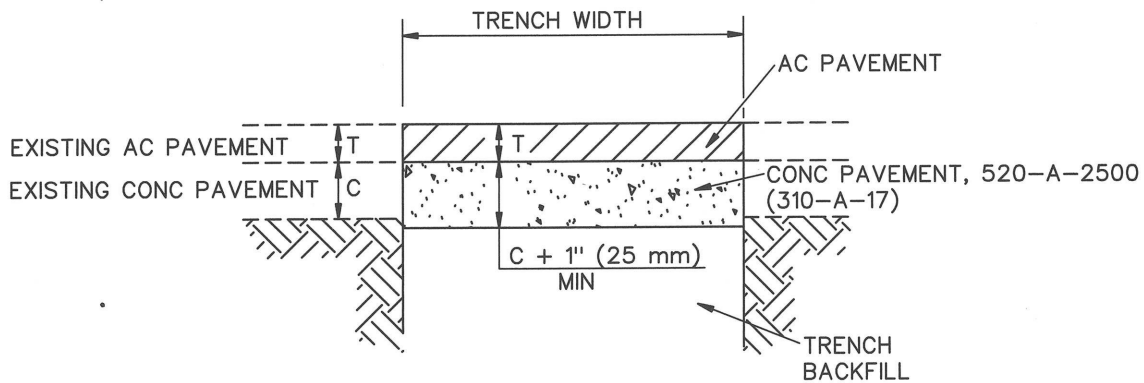

CASE III – AC PVMT ON CONCRETE PVMT

STANDARD PLANS FOR PUBLIC WORKS CONSTRUCTION

PROMULGATED BY THE
PUBLIC WORKS STANDARDS INC.
GREENBOOK COMMITTEE
1993
REV. 1996, 2005, 2009, 2021

**ASPHALT CONCRETE PAVEMENT
REPLACEMENT**

USE WITH STANDARD SPECIFICATIONS FOR PUBLIC WORKS CONSTRUCTION

STANDARD PLAN

133-4

SHEET 1 OF 2

NOTES:

1. TRENCH BACKFILL AND DENSIFICATION SHALL CONFORM TO SSPWC 217-2 AND 306-12.
2. TRENCH RESURFACING SHALL BE PLACED PER SSPWC 306-13.

STANDARD PLANS FOR PUBLIC WORKS CONSTRUCTION

**ASPHALT CONCRETE PAVEMENT
REPLACEMENT**

STANDARD PLAN

133-4

SHEET 2 OF 2

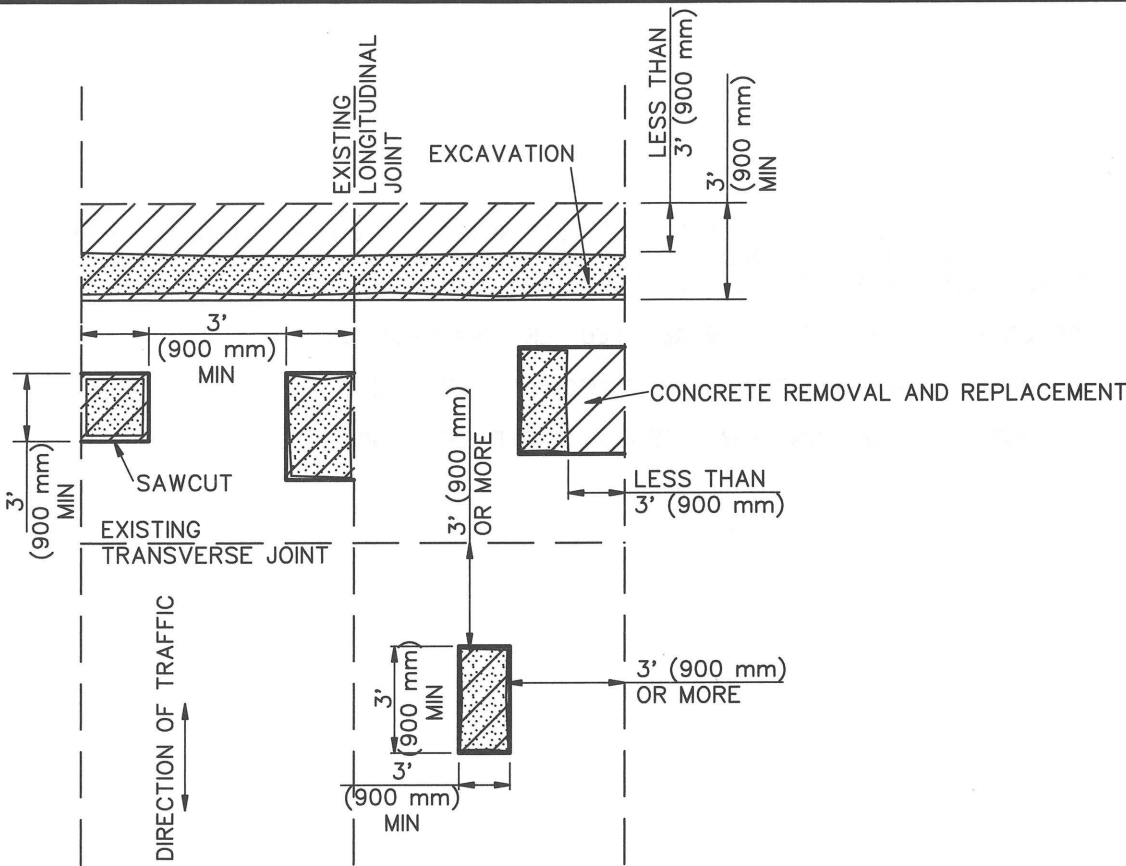

PLAN

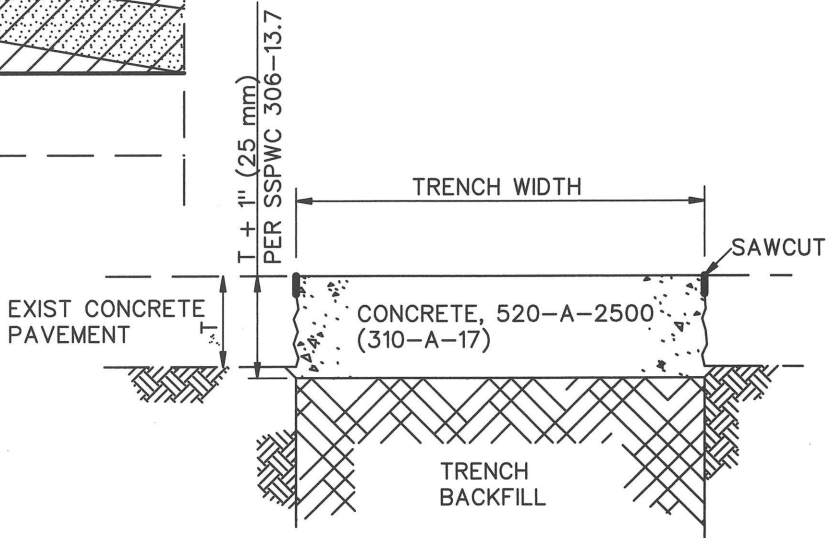
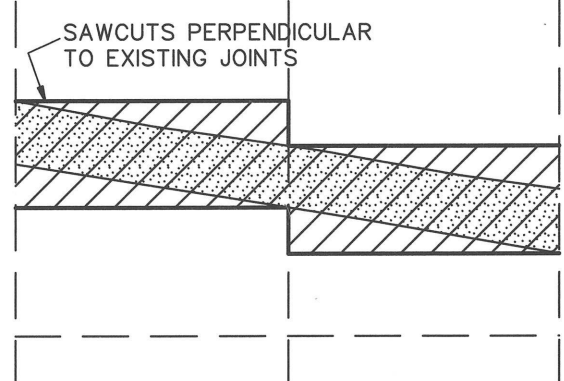

REPLACEMENT SECTION

STANDARD PLANS FOR PUBLIC WORKS CONSTRUCTION

PROMULGATED BY THE
PUBLIC WORKS STANDARDS INC.
GREENBOOK COMMITTEE
1993
REV. 1996, 2005, 2009, 2021

CONCRETE PAVEMENT REPLACEMENT

USE WITH STANDARD SPECIFICATIONS FOR PUBLIC WORKS CONSTRUCTION

STANDARD PLAN

132-4

SHEET 1 OF 2

NOTES:

1. THE EXTENT OF REPAIRS FOR CONCRETE CUTS NOT SHOWN ON THIS STANDARD PLAN OR CUTS MADE WITHIN 3' (900 mm) OF EXISTING PATCHES, CRACKS, OR DETERIORATED SLABS SHALL BE DETERMINED BY THE ENGINEER.
2. CONCRETE PAVEMENT SHALL BE REMOVED PER SSPWC 401-3.1.
3. BACKFILL AND DENSIFICATION SHALL CONFORM TO SSPWC 306-1.3.
4. TEMPORARY RESURFACING SHALL BE PLACED PER SSPWC 306-1.5.1.

STANDARD PLANS FOR PUBLIC WORKS CONSTRUCTION

CONCRETE PAVEMENT REPLACEMENT

STANDARD PLAN

132-4

SHEET 2 OF 2

ATTACHMENT B – POTHOLE LOCATION MAP

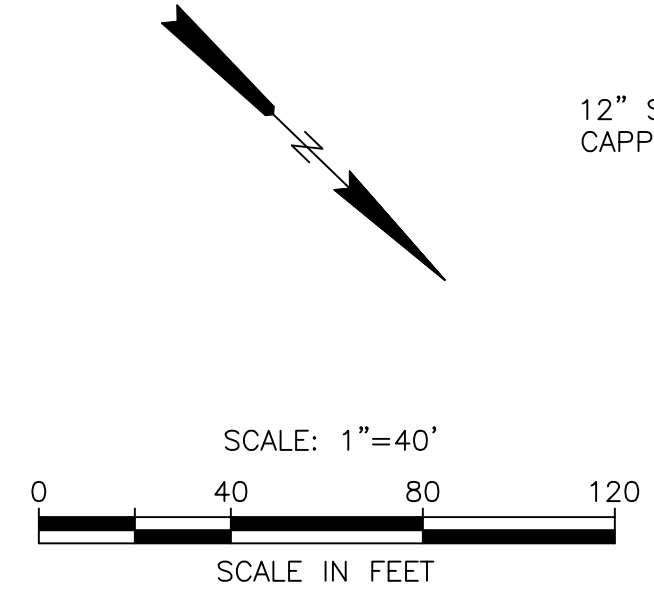

12" STEEL/DIP PER CAPP AWPFP DESIGN PLANS
 SEE CAPP AWPFP DESIGN PLANS FOR CONTINUATION
 FLEXIBLE EXPANSION JOINT
 12" FLGxMJ GV PER CVWD STD DWG W-109

TO POTHOLE
 POTHOLES ALL LOCATION IDENTIFIED BY RED (HIGH PRIORITY) OR ORANGE (MEDIUM PRIORITY) CALLOUTS

DO NOT POTHOLES
 DO NOT POTHOLES LOCATIONS IDENTIFIED BY BLUE (LOW PRIORITY) CALLOUTS

POTHOLE LEGEND

- High Priority
- Medium Priority
- Low Priority

Medium Priority: 19 Potholes
 High Priority: 20 Potholes
Total: 39 Potholes

REQUESTED POTHOLE INFORMATION

Record data on a form, including location of pothole with swing ties

Pothole outline. Measure AC pvtm thickness and photograph hole from over top and to side wall.

Pothole down for cover depth

Pothole down for bottom of pipe/duct bank and size/material

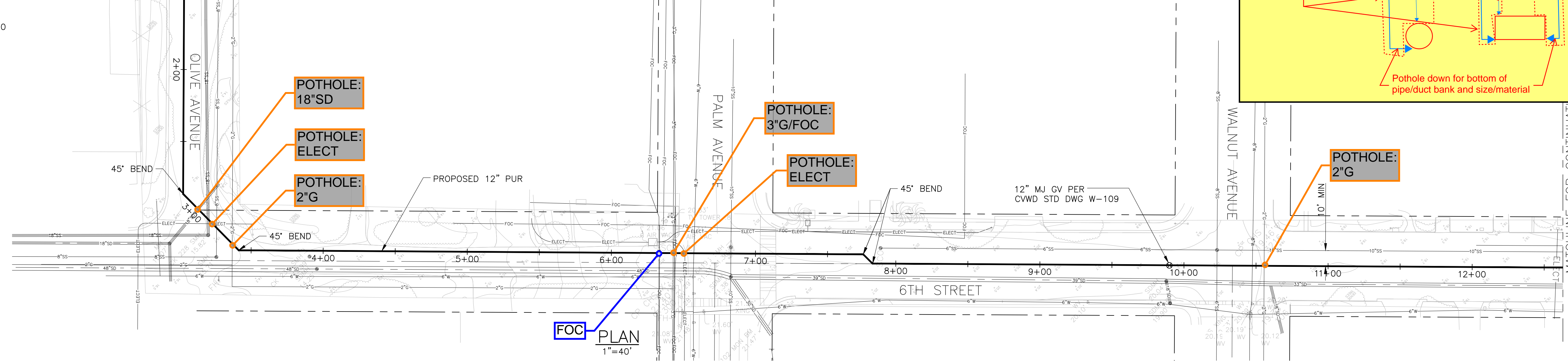

FOC PLAN
 1"=40'

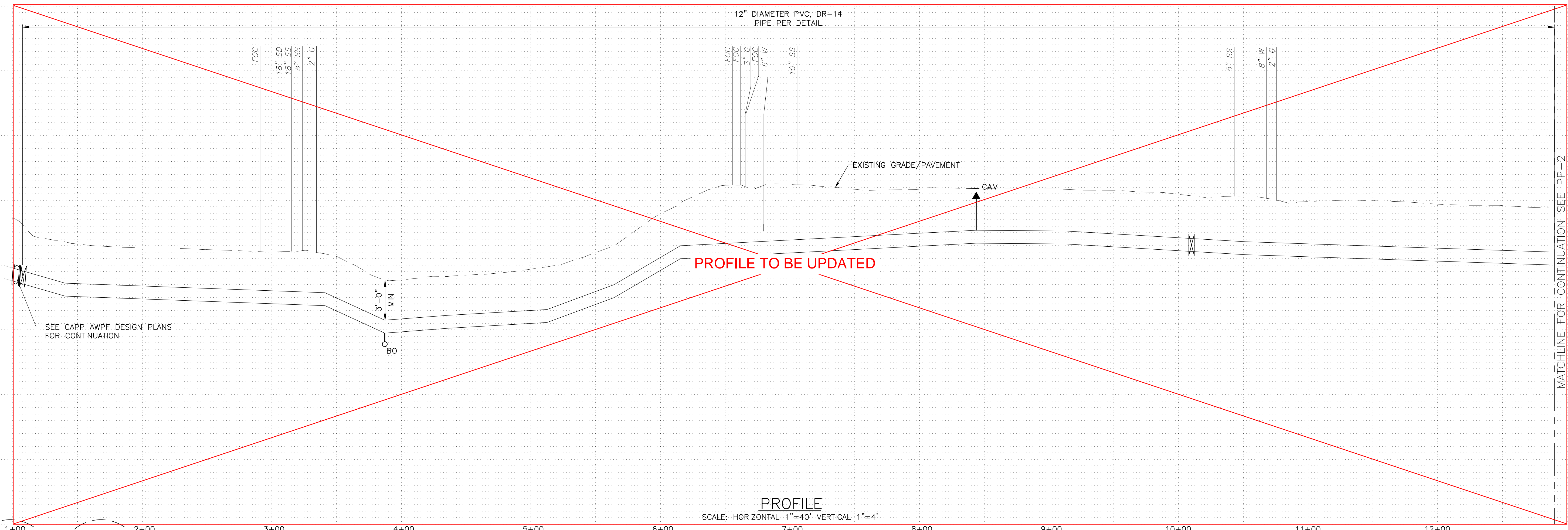

PROFILE
 SCALE: HORIZONTAL 1"=40' VERTICAL 1"=4'

DRAFT-NOT FOR CONSTRUCTION

0" VERIFY SCALES
 BAR IS ONE INCH LONG ON FULL SIZE DRAWING.
 IF NOT ONE INCH LONG ON THIS DRAWING, ADJUST SCALES ACCORDINGLY



REV	DATE	BY	APVD	DESCRIPTION

DESIGNED BY: J. Anketell
 DRAWN BY: C. To
 CHECKED BY: K. Erickson

SUBMITTED: ENGR C
 APPROVED: PROJ ENGR C



CARPINTERIA ADVANCED PURIFICATION PROJECT,
 CONVEYANCE PIPELINE, FINAL DESIGN
CIVIL
PLAN AND PROFILE

DWG NO **PP-1**
 SHEET NO 6 OF
 PROJ NO 0012181.00
 DATE APRIL 2023

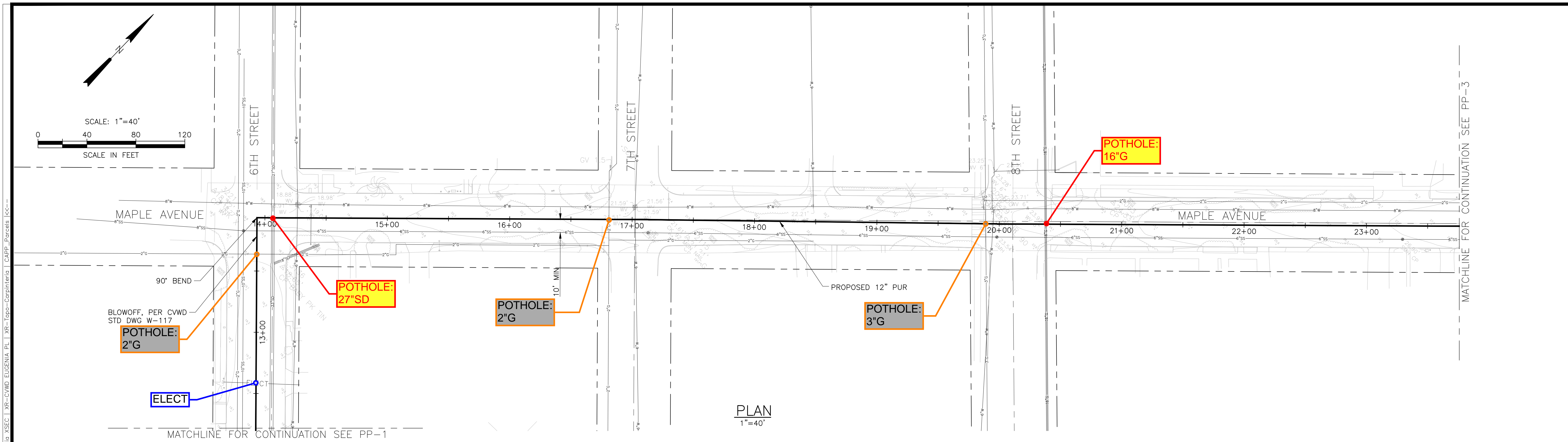

PLAN
1"=40'

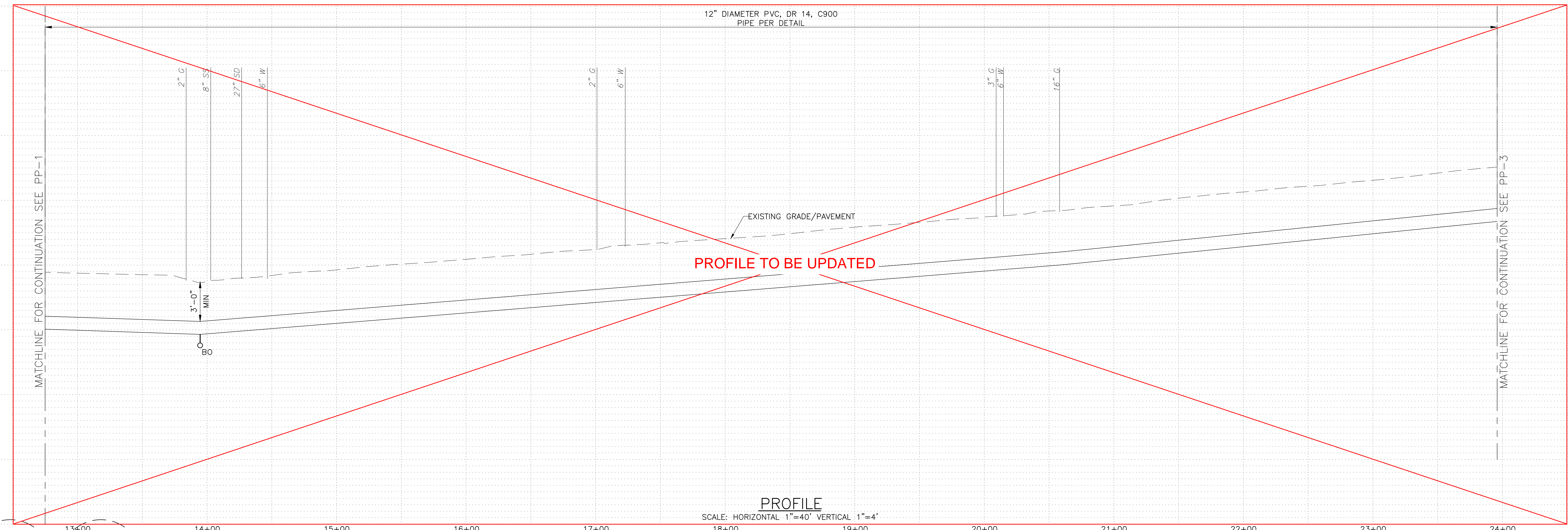

PROFILE
SCALE: HORIZONTAL 1"=40' VERTICAL 1"=4'

DRAFT-NOT FOR CONSTRUCTION

0" = 1" VERIFY SCALES BAR IS ONE INCH LONG ON FULL SIZE DRAWING. IF NOT ONE INCH LONG ON THIS DRAWING, ADJUST SCALES ACCORDINGLY



REV	DATE	BY	APVD	DESCRIPTION

DESIGNED BY: J. Anketell
DRAWN BY: C. To
CHECKED BY: K. Erickson

SUBMITTED: ENGR C
APPROVED: PROJ ENGR C

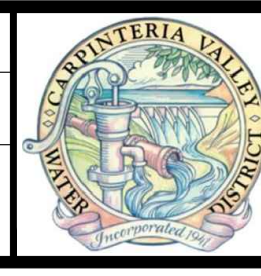

CARPINTERIA VALLEY WATER DISTRICT

CARPINTERIA ADVANCED PURIFICATION PROJECT, CONVEYANCE PIPELINE, FINAL DESIGN
CIVIL
PLAN AND PROFILE

DWG NO **PP-2**
SHEET NO 7 OF
PROJ NO 0012181.00
DATE APRIL 2023

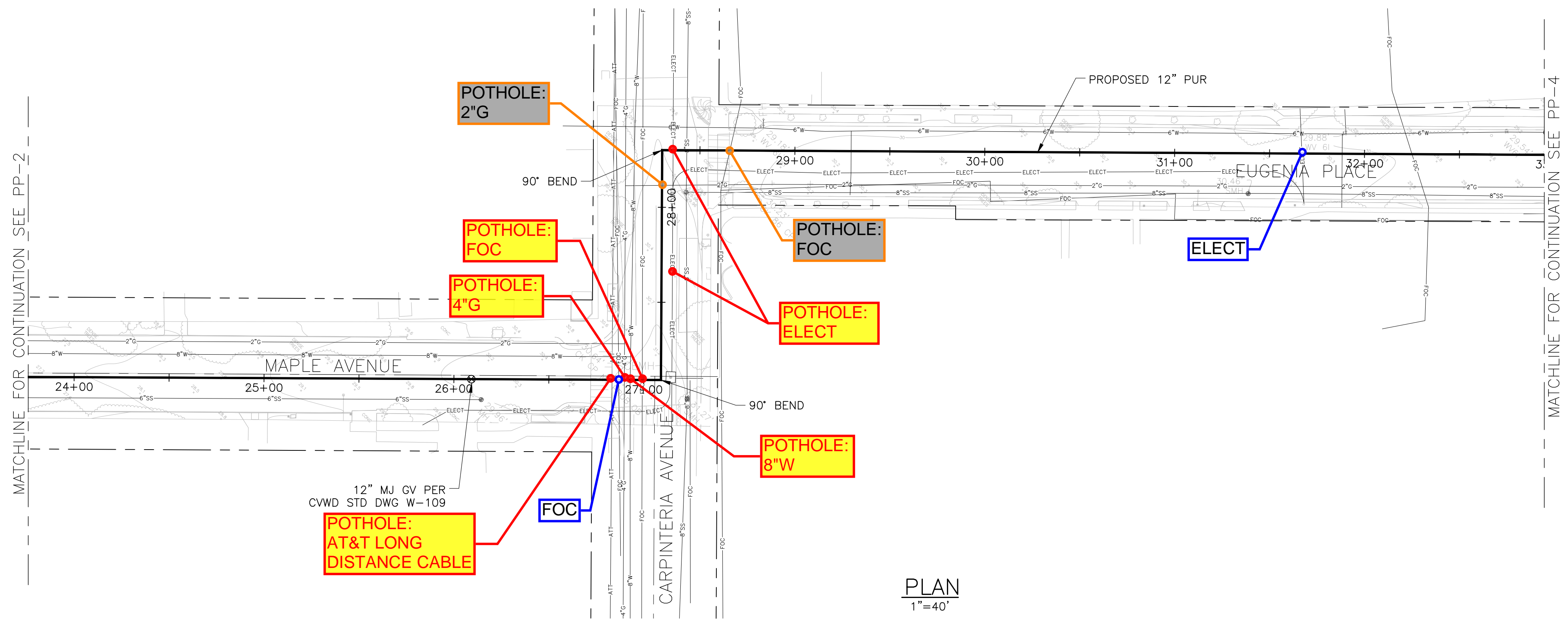
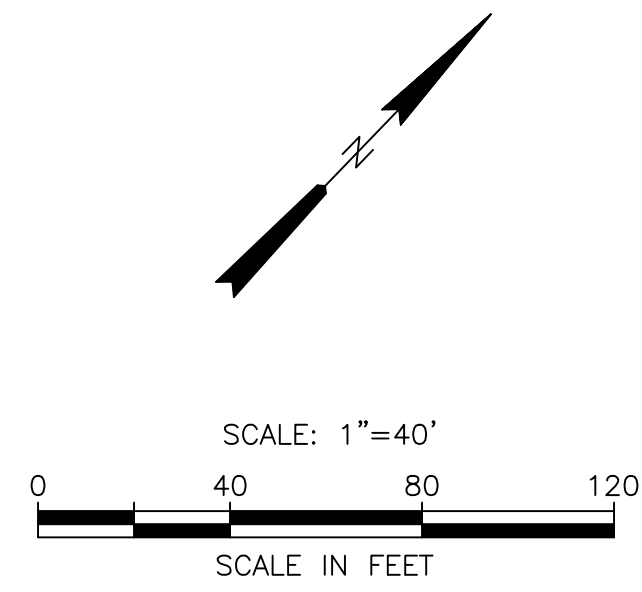

PLAN
1"=40'

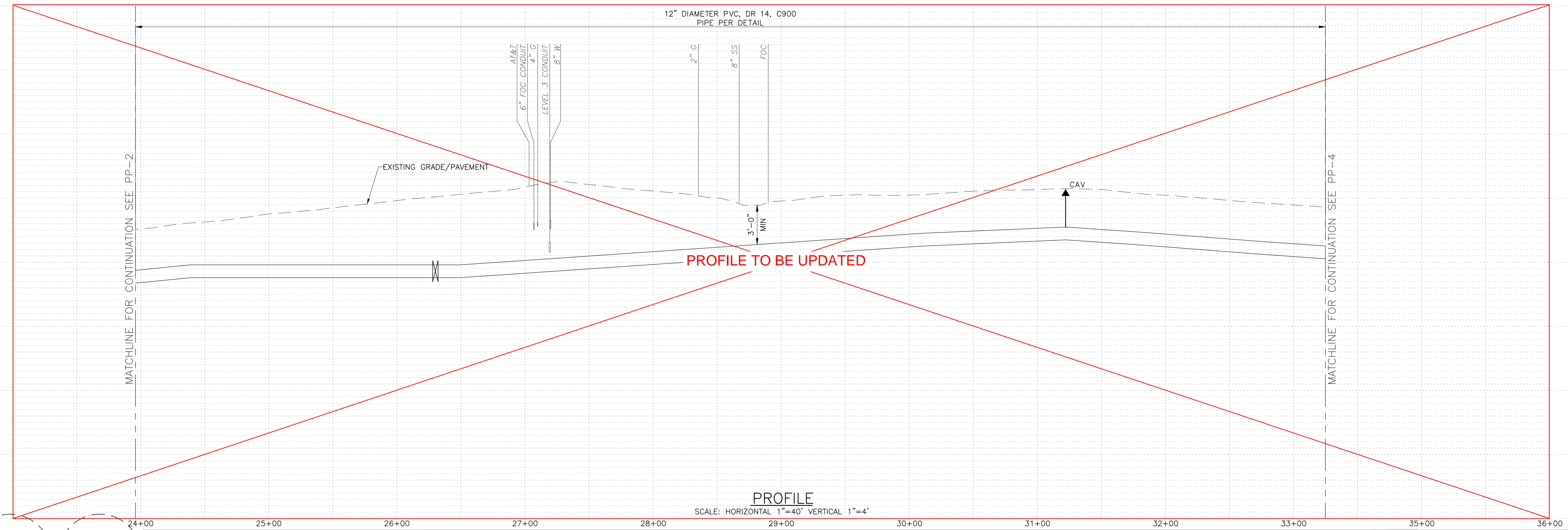

PROFILE
SCALE: HORIZONTAL 1"=40' VERTICAL 1"=4'

DRAFT-NOT FOR CONSTRUCTION

0" = 1" VERIFY SCALES BAR IS ONE INCH LONG ON FULL SIZE DRAWING. IF NOT ONE INCH LONG ON THIS DRAWING, ADJUST SCALES ACCORDINGLY



REV	DATE	BY	APVD	DESCRIPTION

DESIGNED BY:	J. Anketell
DRAWN BY:	C. To
CHECKED BY:	K. Erickson

SUBMITTED:	ENGR	C
APPROVED:	PROJ ENGR	C



CARPINTERIA VALLEY WATER DISTRICT

CARPINTERIA ADVANCED PURIFICATION PROJECT,
CONVEYANCE PIPELINE, FINAL DESIGN
CIVIL
PLAN AND PROFILE

DWG NO	PP-3
SHEET NO	8 OF .
PROJ NO	0012181.00
DATE	APRIL 2023

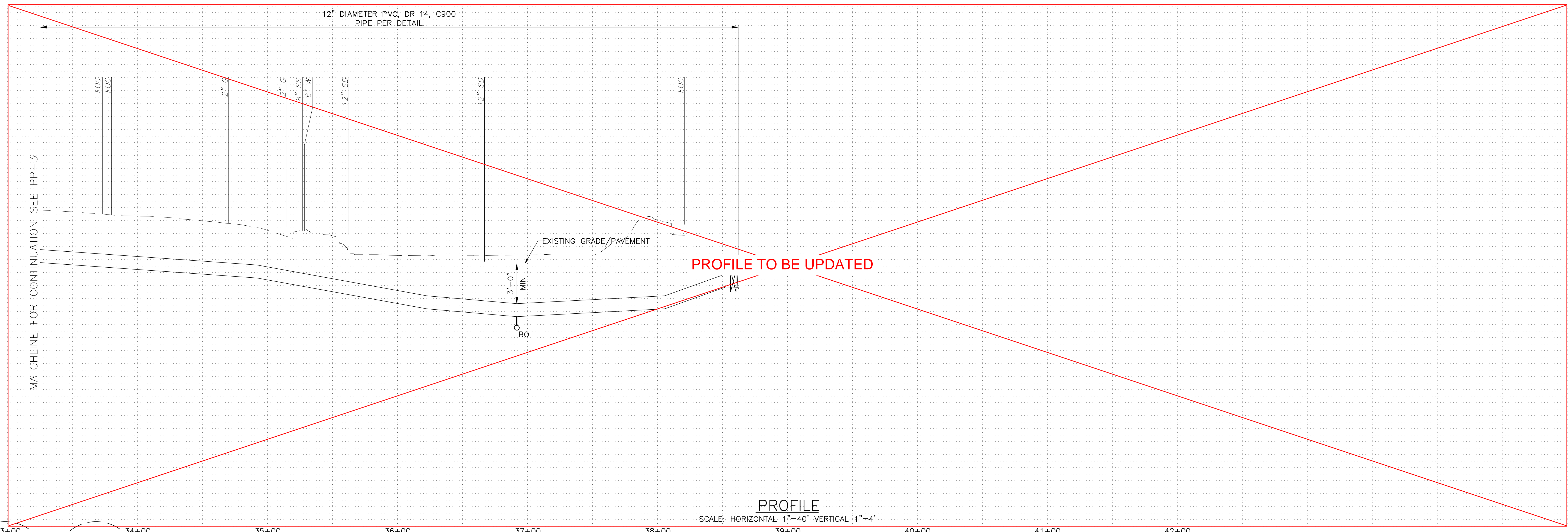
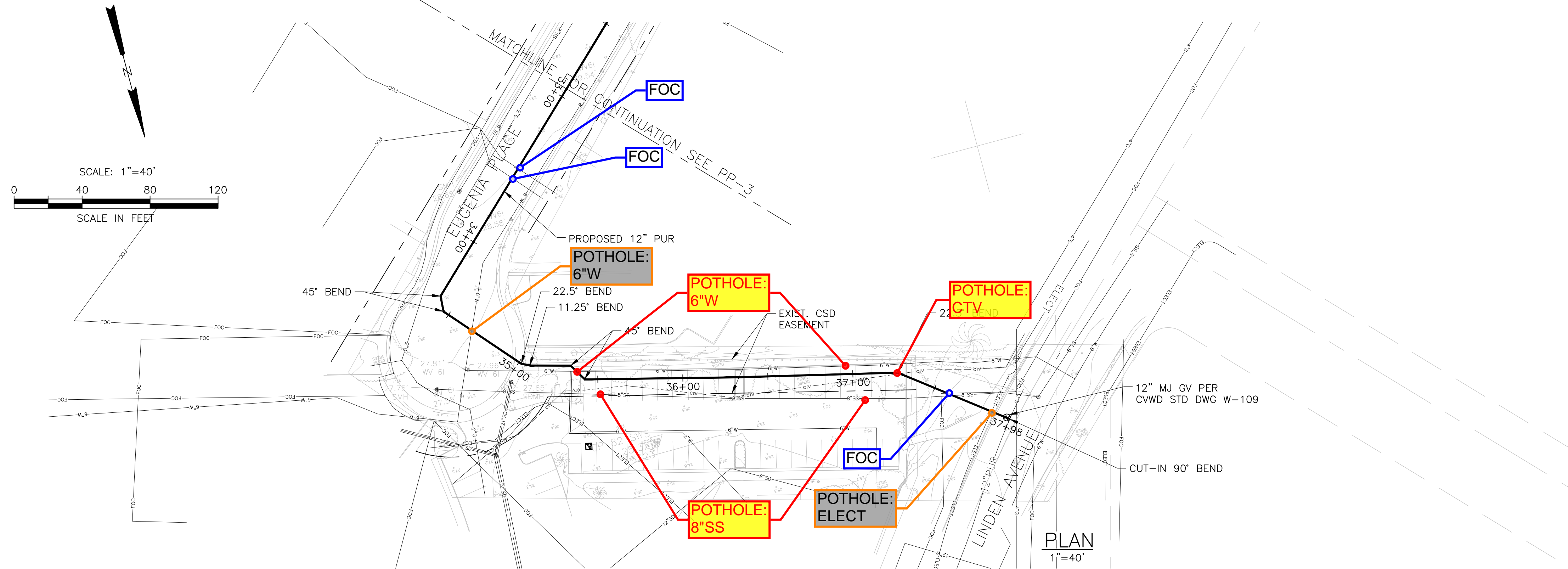

DRAFT-NOT FOR CONSTRUCTION

0" = 1" VERIFY SCALES BAR IS ONE INCH LONG ON FULL SIZE DRAWING. IF NOT ONE INCH LONG ON THIS DRAWING, ADJUST SCALES ACCORDINGLY



REV	DATE	BY	APVD	DESCRIPTION

DESIGNED BY: J. Anketell
 DRAWN BY: C. To
 CHECKED BY: K. Erickson

SUBMITTED: ENGR C
 APPROVED: PROJ ENGR C



CARPINTERIA ADVANCED PURIFICATION PROJECT, CONVEYANCE PIPELINE, FINAL DESIGN
 CIVIL
 PLAN AND PROFILE

DWG NO **PP-4**
 SHEET NO 9 OF
 PROJ NO 0012181.00
 DATE APRIL 2023

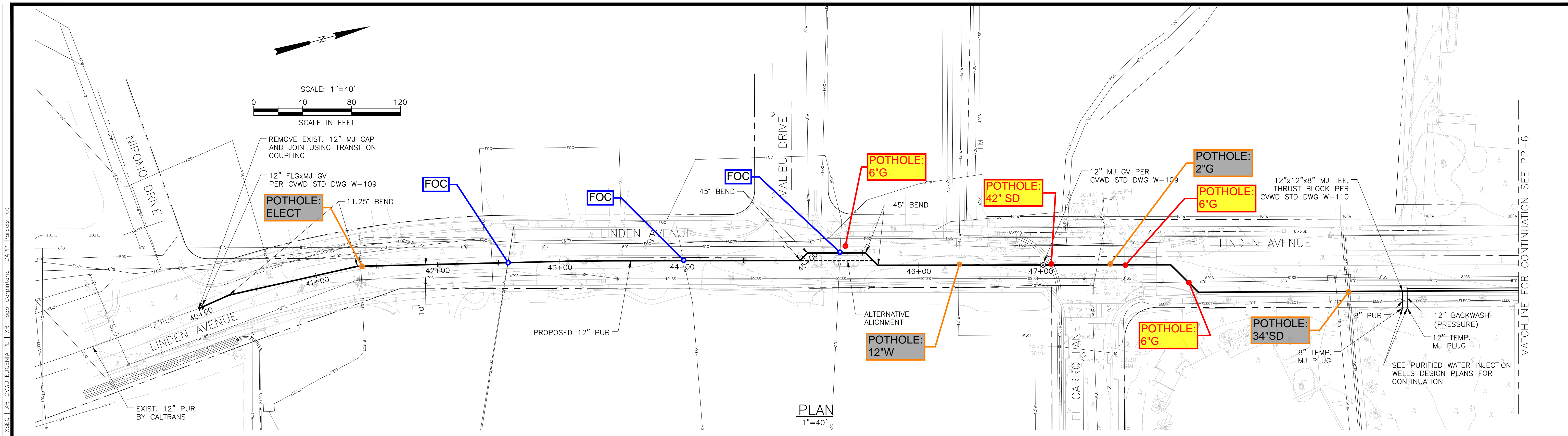

PLAN
1"=40'

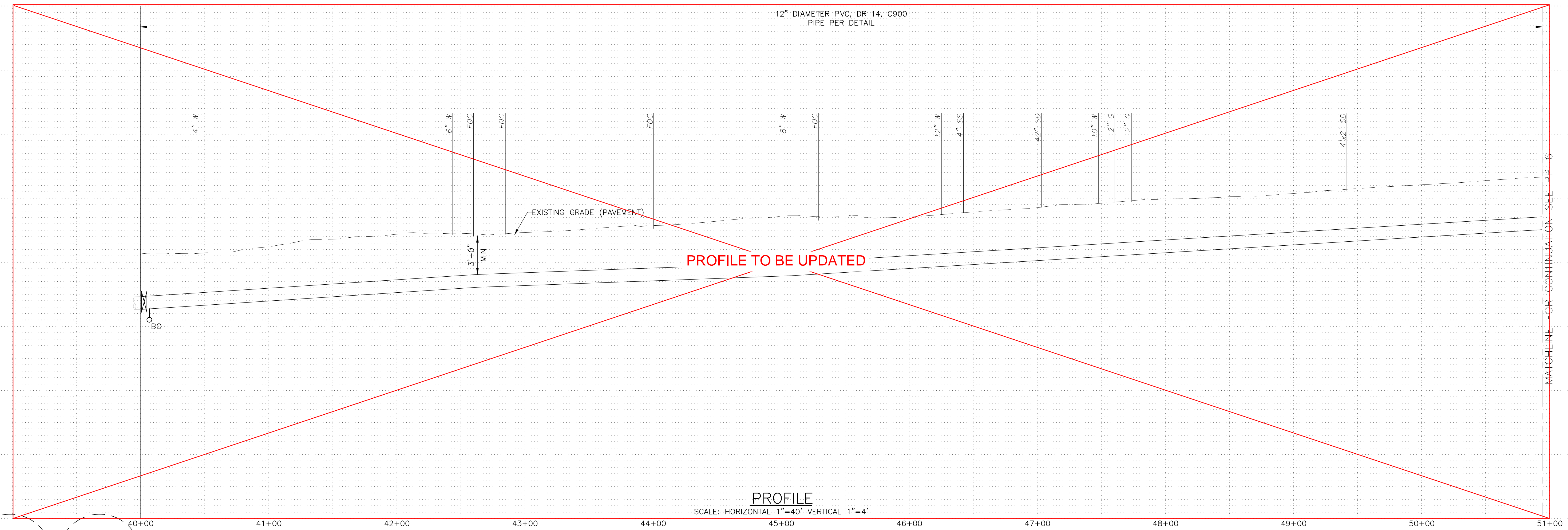

PROFILE
SCALE: HORIZONTAL 1"=40' VERTICAL 1"=4'

DRAFT-NOT FOR CONSTRUCTION

0" = 1" VERIFY SCALES BAR IS ONE INCH LONG ON FULL SIZE DRAWING. IF NOT ONE INCH LONG ON THIS DRAWING, ADJUST SCALES ACCORDINGLY



REV	DATE	BY	APVD	DESCRIPTION

DESIGNED BY: J. Anketell
 DRAWN BY: C. To
 CHECKED BY: K. Erickson

SUBMITTED: ENGR C
 APPROVED: PROJ ENGR C



CARPINTERIA ADVANCED PURIFICATION PROJECT, CONVEYANCE PIPELINE, FINAL DESIGN
 CIVIL
 PLAN AND PROFILE

DWG NO PP-5
 SHEET NO 10 OF
 PROJ NO 0012181.00
 DATE APRIL 2023

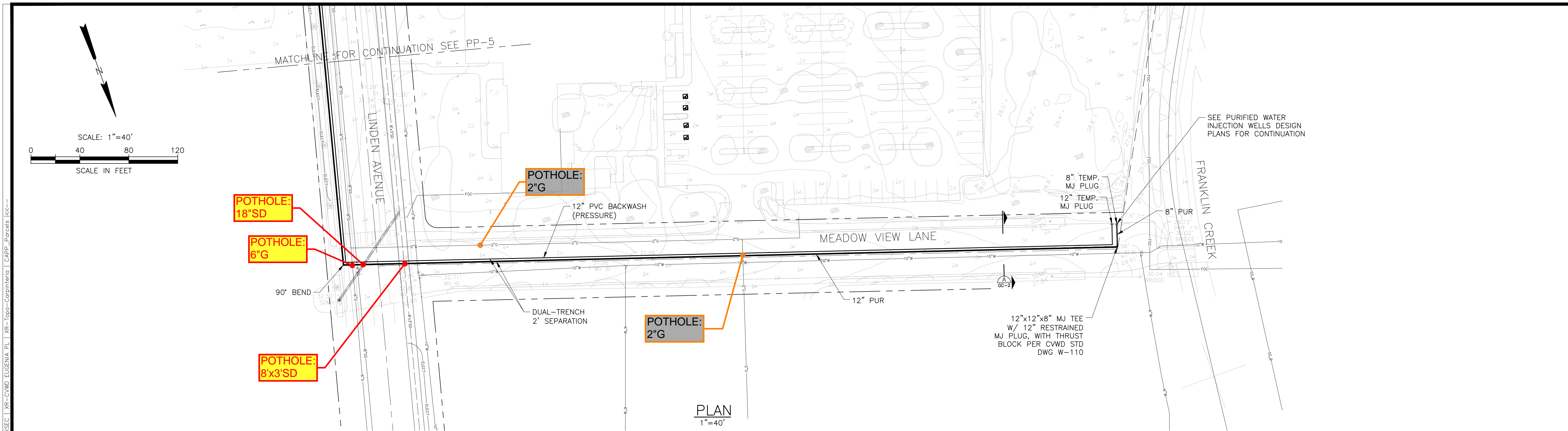

DRAFT-NOT FOR CONSTRUCTION

0" = 1" SCALE BAR IS ONE INCH LONG ON FULL SIZE DRAWING. IF NOT ONE INCH LONG ON THIS DRAWING, ADJUST SCALES ACCORDINGLY



REV	DATE	BY	APVD	DESCRIPTION

DESIGNED BY: J. Anketell
 DRAWN BY: C. To
 CHECKED BY: K. Erickson

SUBMITTED: ENGR C
 APPROVED: PROJ ENGR C



CARPINTERIA VALLEY WATER DISTRICT

CARPINTERIA ADVANCED PURIFICATION PROJECT, CONVEYANCE PIPELINE, FINAL DESIGN
CIVIL
 PLAN AND PROFILE

DWG NO **PP-6**
 SHEET NO 11 OF
 PROJ NO 0012181.00
 DATE APRIL 2023

ATTACHMENT C – POTHOLE INFORMATION FORM

Pothole Information Form

Pothole Number _____
Utility Type (gas, sewer, etc.) _____

Location (Address or
Coordinates) _____

Utility Material (PVC, etc.) _____

Initials of Potholer _____

Utility Owner (if known) _____

Date _____

Surface Material: _____ Asphalt
_____ Concrete
_____ Other: _____

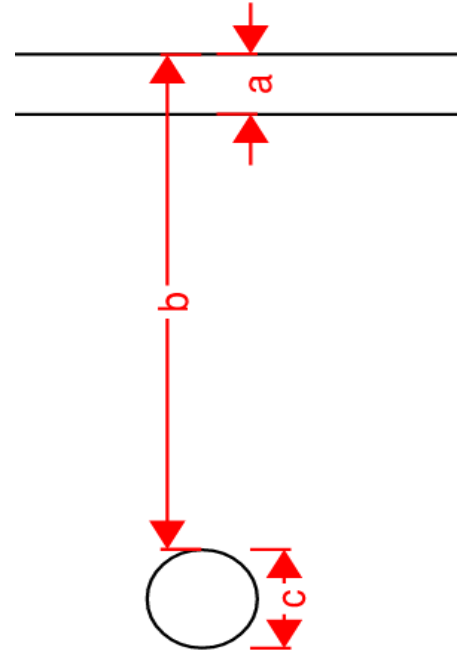

Depth/thickness of surface material (a) (inches) _____

Depth from ground surface to top of utility (b) (inches) _____

Outside diameter of utility (or height, if not circular) (c)
(inches) _____

Width of utility if different from height (inches) _____

Utility direction (NW-SE, N-S, etc.) _____

If utility is encased or if multiple conduits are present, sketch cross sectional layout below:

Utility Photo

Site Photo